

UNIFIED FACILITIES MANUAL (UFM)

O&M MANUAL: STANDARD PRACTICE FOR AIRFIELD PAVEMENT CONDITION SURVEYS



FOREWORD

Unified Facilities Manuals (UFM) provide non-mandatory, informational guidance in support of Unified Facilities Criteria (UFC) with a specific focus on facilities operations, and maintenance. Only UFC establish enforceable requirements. UFM are For Information Only (FIO) and exist to help users understand and apply UFC requirements.

The purpose of UFM is to share operational procedures, maintenance practices, and practical examples that support effective implementation of UFC criteria during operations and maintenance activities. UFM may include recommended procedures, checklists, illustrations, or explanatory material, but they do not create new requirements, modify UFC content, or establish mandatory standards.

UFM are developed by Discipline Working Groups (DWGs) and published by the Military Services under MIL-STD-3007. Because they are not criteria, they do not require Coordinating Panel (CP) or Engineering Senior Executive Panel (ESEP) approval.

UFM content may be referenced or incorporated into operations, maintenance, or project documentation at the discretion of project delivery teams, but it is not binding unless explicitly included in contract requirements.

UNIFIED FACILITIES MANUAL (UFM)

O&M MANUAL: STANDARD PRACTICE FOR
AIRFIELD PAVEMENT CONDITION SURVEYS

TABLE OF CONTENTS

CHAPTER 1 INTRODUCTION	1
1-1 PURPOSE AND SCOPE.	1
1-2 APPLICABILITY.	2
1-3 GLOSSARY.	2
1-4 REFERENCES.	2
CHAPTER 2 INSPECTION PROCEDURE	3
2-1 PAVEMENT SECTIONING.	3
2-2 SAMPLE UNITS.	3
2-2.1 Definition.	3
2-2.2 Sample Unit Sizes.	3
2-2.3 Examples.	3
2-3 NETWORK-LEVEL INSPECTION.	4
2-3.1 Determining the Number of Sample Units to be Inspected.	4
2-3.2 Selecting Sample Units to Inspect.	5
2-4 PROJECT-LEVEL INSPECTION.	5
2-4.1 Determining the Number of Sample Units to be Inspected.	5
2-4.2 Selecting Sample Units to Inspect.	7
2-5 SELECTION OF ADDITIONAL SAMPLE UNITS.	7
2-6 PAVEMENT DISTRESS RECORDING.	8
2-6.1 Example PCI Survey Sheets: Airfield Pavements.	8
CHAPTER 3 PCI CALCULATION PROCEDURE	11
3-1 INTRODUCTION.	11
3-2 CALCULATION OF A SAMPLE UNIT PCI FOR ASPHALT-SURFACED PAVEMENTS.	11
3-2.1 Step 1: Determine Deduct Values.	14
3-2.2 Step 2: Determine the Maximum Allowable Number of Deducts (<i>m</i>). .	15
3-2.3 Step 3: Determine the Maximum Corrected Deduct Value (CDV).	16
3-2.4 Step 4: Calculate PCI by Subtracting the Maximum CDV from 100. ...	18

3-3	CALCULATION OF A SAMPLE UNIT PCI FOR CONCRETE-SURFACED PAVEMENTS.	18
3-3.1	Step 1: Determine Deduct Values.	18
3-3.2	Step 2: Determine the Maximum Allowable Number of Deducts (<i>m</i>). .	20
3-3.3	Step 3: Determine the Maximum CDV.	20
3-3.4	Step 4: Calculate the PCI by Subtracting the Maximum CDV from 100...	20
3-4	CALCULATION OF THE PCI FOR A PAVEMENT SECTION.	22
3-5	EXTRAPOLATING DISTRESS QUANTITIES FOR A PAVEMENT SECTION.	23
APPENDIX A PAVEMENT CONDITION INDEX (PCI) DISTRESS DEFINITIONS - ASPHALT-SURFACED AIRFIELDS.		25
APPENDIX B PAVEMENT CONDITION INDEX (PCI) DISTRESS DEFINITIONS - CONCRETE-SURFACED AIRFIELDS		72
APPENDIX C PAVEMENT CONDITION INDEX (PCI) DISTRESS DEDUCT CURVES FOR ASPHALT (BITUMINOUS) AIRFIELD PAVEMENTS		111
APPENDIX D PAVEMENT CONDITION INDEX (PCI) DISTRESS DEDUCT CURVES FOR CONCRETE AIRFIELD PAVEMENTS		131
APPENDIX E BLANK FORMS.		148
APPENDIX D GLOSSARY		155
APPENDIX E REFERENCES		158

FIGURES

Figure 2-1 Example Division of a Jointed Rigid Pavement Section into Sample Units of 20 Slabs	4
Figure 2-2 Example Division of a Flexible Pavement Section into Sample Units	4
Figure 2-3 Selection of the Minimum Number of Sample Units	6
Figure 2-4 Example of Systematic Random Sampling	7
Figure 2-5 Asphalt-Surfaced Airfield Pavements Example PCI Survey Sheet	9
Figure 2-6 Concrete-Surfaced Airfield Pavements Example PCI Survey Sheet	10
Figure 3-1 Asphalt-Surfaced Airfield PCI Survey Data Sheet Example	12
Figure 3-2 PCI Calculation Steps for Sample Unit	13
Figure 3-3 AC Pavement Deduct Curve for Alligator Cracking Distress	15
Figure 3-4 Determination of Maximum Allowable Deducts (<i>m</i>) for Airfield Pavements	15
Figure 3-5 PCI Calculation Sheet for Example Sample Unit Shown in Figure 3-1	17
Figure 3-6 Correction Curves for AC-Surfaced Airfield Pavements	18

Figure 3-7 Concrete-Surfaced Airfield PCI Survey Data Sheet Example	19
Figure 3-8 PCI Calculation Sheet for the Example Sample Unit Shown in Figure 3-7	21
Figure A-1 Low-Severity Alligator Cracking	27
Figure A-2 Medium-Severity Alligator Cracking	27
Figure A-3 High-Severity Alligator Cracking	28
Figure A-4 Bleeding	29
Figure A-5 Bleeding	30
Figure A-6 Low-Severity Block Cracking	31
Figure A-7 Low-Severity Block Cracking	32
Figure A-8 Medium-Severity Block Cracking	32
Figure A-9 Medium-Severity Block Cracking	33
Figure A-10 High-Severity Block Cracking	33
Figure A-11 High-Severity Block Cracking	34
Figure A-12 Corrugation	35
Figure A-13 Low-Severity Corrugation	36
Figure A-14 Medium-Severity Corrugation	36
Figure A-15 High-Severity Corrugation	37
Figure A-16 Low-Severity Depression	38
Figure A-17 Medium-Severity Depression	39
Figure A-18 High-Severity Depression	39
Figure A-19 High-Severity Depression	40
Figure A-20 Jet Blast Erosion	41
Figure A-21 Low-Severity Joint Reflection Cracking	42
Figure A-22 Medium-Severity Joint Reflection Cracking	43
Figure A-23 High-Severity Joint Reflection Cracking	43
Figure A-24 Low-Severity L&T Cracking	45
Figure A-25 Medium-Severity L&T Cracking	45
Figure A-26 High-Severity L&T Cracking	46
Figure A-27 Low-Severity PFC L&T Cracking	47
Figure A-28 Medium-Severity PFC L&T Cracking	48
Figure A-29 Medium-Severity PFC L&T Cracking	49
Figure A-30 High-Severity PFC L&T Cracking	50
Figure A-31 Oil Spill	51

Figure A-32 Low-Severity Patching	52
Figure A-33 Medium-Severity Patching	52
Figure A-34 High-Severity Patching	54
Figure A-35 Polished Aggregate	55
Figure A-36 Low-Severity Raveling (Dense Mix)	56
Figure A-37 Medium-Severity Raveling (Dense Mix)	57
Figure A-38 High-Severity Raveling (Dense Mix)	57
Figure A-39 Low-Severity Raveling (Slurry Seal/Coal Tar Over Dense Mix)	58
Figure A-40 Medium-Severity Raveling (Slurry Seal/Coal Tar Over Dense Mix)	59
Figure A-41 High-Severity Raveling (Slurry Seal/Coal Tar Over Dense Mix)	59
Figure A-42 Low-Severity Raveling (PFC)	60
Figure A-43 Medium-Severity Raveling (PFC)	61
Figure A-44 Medium-Severity Raveling (PFC)	61
Figure A-45 High-Severity Raveling (PFC)	62
Figure A-46 Rutting	63
Figure A-47 Low-Severity Shoving	65
Figure A-48 Medium-Severity Shoving	65
Figure A-49 High-Severity Shoving	66
Figure A-50 Slippage Cracking	67
Figure A-51 Low-Severity Swell	68
Figure A-52 Medium-Severity Swell	69
Figure A-53 High-Severity Swell	69
Figure A-54 Low-Severity Weathering	70
Figure A-55 Medium-Severity Weathering	71
Figure A-56 High-Severity Weathering	71
Figure B-1 Low-Severity Blowup	74
Figure B-2 Low-Severity Blowup	74
Figure B-3 Medium-Severity Blowup	75
Figure B-4 High-Severity Blowup	75
Figure B-5 Low-Severity Corner Break	77
Figure B-6 Medium-Severity Corner Break	77
Figure B-7 High-Severity Corner Break	78
Figure B-8 Low-Severity Linear Cracks	79

Figure B-9 Medium-Severity Linear Cracks	80
Figure B-10 High-Severity Linear Cracks	80
Figure B-11 Cracks (Reinforced PCC)	81
Figure B-12 Low-Severity “D” Cracking	82
Figure B-13 Medium-Severity “D” Cracking	83
Figure B-14 High-Severity “D” Cracking	83
Figure B-15 Low-Severity Joint Seal Damage	85
Figure B-16 Medium-Severity Joint Seal Damage	86
Figure B-17 High-Severity Joint Seal Damage	86
Figure B-18 Low-Severity Small Patch	88
Figure B-19 Medium-Severity Small Patch	88
Figure B-20 High-Severity Small Patch	89
Figure B-21 Low-Severity Large Patch	90
Figure B-22 Medium-Severity Large Patch	90
Figure B-23 High Severity Large Patch	91
Figure B-24 Popouts	92
Figure B-25 Pumping	93
Figure B-26 Pumping	93
Figure B-27 Low-Severity Scaling	95
Figure B-28 Medium-Severity Scaling	95
Figure B-29 High-Severity Scaling	96
Figure B-30 Low-Severity Settlement or Faulting	97
Figure B-31 Low-Severity Settlement or Faulting	98
Figure B-32 High-Severity Settlement or Faulting	98
Figure B-33 Low-Severity Shattered Slab/Intersecting Cracks	99
Figure B-34 Medium-Severity Shattered Slab/Intersecting Cracks	100
Figure B-35 High-Severity Shattered Slab/Intersecting Cracks	100
Figure B-36 Shrinkage Cracks	101
Figure B-37 Low-Severity Joint Spall	103
Figure B-38 Medium-Severity Joint Spall	103
Figure B-39 High-Severity Joint Spall	104
Figure B-40 High-Severity Joint Spall	104
Figure B-41 Low-Severity Corner Spall	106

Figure B-42 Medium-Severity Corner Spall	106
Figure B-43 High-Severity Corner Spall	107
Figure B-44 Low-Severity ASR	109
Figure B-45 Medium-Severity ASR	109
Figure B-46 High-Severity ASR	110
Figure C-1 Deduct Curves for Alligator Cracking (41) {1}	111
Figure C-2 Deduct Curve for Bleeding (42) {2}	112
Figure C-3 Deduct Curves for Block Cracking (43) {3}	113
Figure C-4 Deduct Curves for Corrugation (44) {4}	114
Figure C-5 Deduct Curves for Depression (45) {5}	115
Figure C-6 Deduct Curve for Jet Blast Erosion (46) {6}	116
Figure C-7 Deduct Curves for Joint Reflection Cracking (47- English Units) {7}	117
Figure C-8 Deduct Curves for Joint Reflection Cracking (47- Metric Units) {7}	118
Figure C-9 Deduct Curves for Longitudinal/Transverse (48- English Units) {8}	119
Figure C-10 Deduct Curves for Longitudinal/Transverse (48- Metric Units) {8}	120
Figure C-11 Deduct Curve for Oil Spillage (49) {9}	121
Figure C-12 Deduct Curves for Patching/Utility Cut (50) {10}	122
Figure C-13 Deduct Curve for Polished Aggregate (51) {11}	123
Figure C-14 Deduct Curves for Raveling (52) {12}	124
Figure C-15 Deduct Curves for Rutting (53) {13}	125
Figure C-16 Deduct Curves for Shoving (54) {14}	126
Figure C-17 Deduct Curve for Slippage Cracking (55) {15}	127
Figure C-18 Deduct Curves for Swell (56) {16}	128
Figure C-19 Deduct Curves for Weathering (57) {17}	129
Figure C-20 Correct Deduct Curves for Asphalt Airfields	130
Figure D-1 Deduct Curves for Blowup (61) {1}	131
Figure D-2 Deduct Curves for Corner Break (62) {2}	132
Figure D-3 Deduct Curves for Cracking (63) {3}	133
Figure D-4 Deduct Curves for Durability Cracking (64) {4}	134
Figure D-5 Deduct Values for Joint Seal Damage (65) {5}	135
Figure D-6 Deduct Curves for Small Patch (66) {6}	136
Figure D-7 Deduct Curves for Patching/Utility Cut (67) {7}	137
Figure D-8 Deduct Curve for Popouts (68) {8}	138

Figure D-9 Deduct Curve for Pumping (69) {9}	139
Figure D-10 Deduct Curves for Scaling (70) {10}	140
Figure D-11 Deduct Curves for Settlement (71) {11}	141
Figure D-12 Deduct Curves for Shattered Slab (72) {12}	142
Figure D-13 Distress Curve for Shrinkage Cracks (73) {13}	143
Figure D-14 Deduct Curves for Joint Spall (74) {14}	144
Figure D-15 Deduct Curves for Corner Spalling (75) {15}	145
Figure D-16 Deduct Curves for ASR (76) {16}	146
Figure D-17 Corrected Deduct Value Curves for Concrete	147
Figure E-1 Airfield Asphalt Pavement Condition Data Survey Sheet (Manual)	149
Figure E-2 Airfield Concrete Pavement Condition Data Survey Sheet (Manual)	150
Figure E-3 AC Airfield Pavement Condition Survey Data Sheet (Automated)	151
Figure E-4 PCC Airfield Pavement Condition Survey Data Sheet (Automated)	152
Figure E-5 PCI Calculation Form	153
Figure E-6 Section/Branch Report Form	154
Figure F-1 Pavement Condition Index (PCI) and Simplified PCI Rating Scales	156

TABLES

Table 2-1 Example of Network-Level Sampling Criteria Used by Some Agencies	5
Table 3-1 Calculation of Deduct Values for Distresses Shown in Figure 3-1	14
Table 3-2 Calculation of Deduct Values for Distresses Shown in Figure 3-7	20
Table 3-3 Medium-Severity Alligator Cracking in Five Surveyed Sample Units	24
Table 3-4 Medium-Severity Alligator Cracking in an Additional Sample Unit	24
Table A-1 Frequently Occurring Problems in Asphalt Pavement Distress Identification	25
Table A-2 Corrugation Measurement Criteria	35
Table A-3 Maximum Depth of Depression	38
Table A-4. Mean Rut Depth Criteria	63
Table A-5. Shoving Criteria	64
Table A-6. Swell Criteria	68
Table B-1 Frequently Occurring Problems In Pavement Distress Identification	72
Table B-2. Difference in Elevation	96
Table B-3 Severity Levels of Spalling	102

EQUATIONS

Equation 2-1 Minimum Sample Units 6
Equation 3-1 Allowable Number of Deducts for Airfields 16
Equation 3-2 Area Weighted Averaging for Unequally Sized Sample Units 22
Equation 3-3 Area Weighted Average PCI for Additional Sample Units 22
Equation 3-4 Section PCI for Additional Sample Units 22

CANCELLED

CHAPTER 1 INTRODUCTION

1-1 PURPOSE AND SCOPE.

1-1.1 This Unified Facilities Manual (UFM) provides the procedure for performing a pavement condition survey at all airfields with present or potential DOD missions. This UFM is intended for use by all personnel responsible for such surveys.

1-1.2 The objectives of a pavement condition survey are to determine the present condition of the pavement in terms of apparent structural integrity and operational surface condition, to provide a common index for comparing the condition and performance of pavements at all air stations along with a rational basis for justification of pavement repair projects, and to provide feedback on pavement performance for validating and improving current pavement design, evaluation, and maintenance procedures.

1-1.3 The airfield pavement condition survey is a visual inspection of both rigid and flexible pavement for signs of pavement distress. The pavement condition index (PCI) is a numerical rating that indicates the type and severity of the inspected distress. The airfield condition survey and the resulting PCI are the primary means of obtaining and recording important airfield pavement performance data. This UFM describes the condition survey of both flexible pavements (all pavements with conventional bituminous concrete surfaces) and rigid pavements (jointed portland cement concrete [PCC] pavements) and the procedure for determining the PCI of the inspected pavement.

1-1.4 The pavement network is divided into branches that are in turn divided into sections. Each section is divided into sample units. The type and severity of pavement distress is assessed by visual inspection of the pavement sample units. The quantity of the distress is measured as described in Appendix A (flexible pavement) and Appendix B (rigid pavement). The distress data are used to calculate the PCI for each sample unit. The PCI of the pavement section is determined based on the PCI of the inspected sample units within the section. The distresses can be numbered using several conventions. Within this UFM, two numbering conventions are presented. One uses the convention adopted within the PAVER software, which starts the numbering of flexible distresses at 41 and continues through 57. For rigid pavement, the distresses start with 61 and continue through 76. This is done to ensure the distresses for the flexible and rigid airfield distresses have unique numerical identifiers and to allow for separate distresses for flexible and rigid roadways to have unique numerical identifiers from 1 to 39. The second convention provided in Appendix A and Appendix B is consistent with ASTM D5340 and is contained in braces: {#}. This numbering convention produces multiple distresses for the same numerical identifier and should be used with caution.

For additional information on performing pavement condition surveys for NATO countries, refer to STANAG 7181.

1-2 APPLICABILITY.

This UFM applies to all Service elements and contractors performing airfield pavement condition surveys.

1-3 GLOSSARY.

Appendix F contains a list of acronyms, abbreviations, and definitions.

1-4 REFERENCES.

Appendix G contains a list of references used in this document. The publication date of the code or standard is not included in this document. Unless otherwise specified, the most recent edition of the referenced publication applies.

CANCELLED

CHAPTER 2 INSPECTION PROCEDURE

2-1 PAVEMENT SECTIONING.

The first step in the condition survey is the designation of pavement sections. Each branch, such as a runway or taxiway, is divided into sections that are definable in terms of the same design, the same construction history, the same traffic area, and generally the same overall condition. Generally, sections are determined from pavement design and construction records and can be further subdivided as deemed necessary based on a preliminary survey. It is important that all pavement in a given section be such that it is considered uniform. For example, the center portion of some runways in the traffic lanes are separate sections from the portion outside the traffic lanes.

2-2 SAMPLE UNITS.

2-2.1 Definition.

A sample unit is a defined portion of a pavement section designated only for the purpose of pavement inspection.

2-2.2 Sample Unit Sizes.

2-2.2.1 Asphalt-Surfaced Airfields.

For asphalt-surfaced airfields, each sample unit area is defined as $5,000 \pm 2,000$ square feet (465 ± 186 square meters). Note that sample unit sizes close to the recommended mean are preferred for accuracy.

2-2.2.2 Concrete-Surfaced Airfields.

For concrete airfields with joints spaced less than or equal to 25 feet (7.6 meters), the recommended sample unit size is 20 ± 8 slabs. For slabs with joints spaced greater than 25 feet (7.6 meters), imaginary joints less than or equal to 25 feet (7.6 meters) apart and in perfect condition are assumed. For example, if slabs have joints spaced 60 feet (18.3 meters) apart, imaginary joints are assumed at 20 feet (6.1 meters). Thus, each slab is counted as three slabs for the purpose of pavement inspection. This is needed because the deduct values were developed for jointed concrete slabs less than or equal to 25 feet (7.6 meters).

2-2.3 Examples.

Figures 2-1 and 2-2, respectively, illustrate the division of a jointed rigid pavement and flexible pavement section into sample units. Each sample unit is numbered where it is identifiable for future inspections, maintenance needs, or statistical sample purposes. Inspect each of the selected sample units and determine its PCI. The PCI of a pavement section is determined by the size-weighted average of the PCI of each sample unit inspected within the section.

Figure 2-1 Example Division of a Jointed Rigid Pavement Section into Sample Units of 20 Slabs

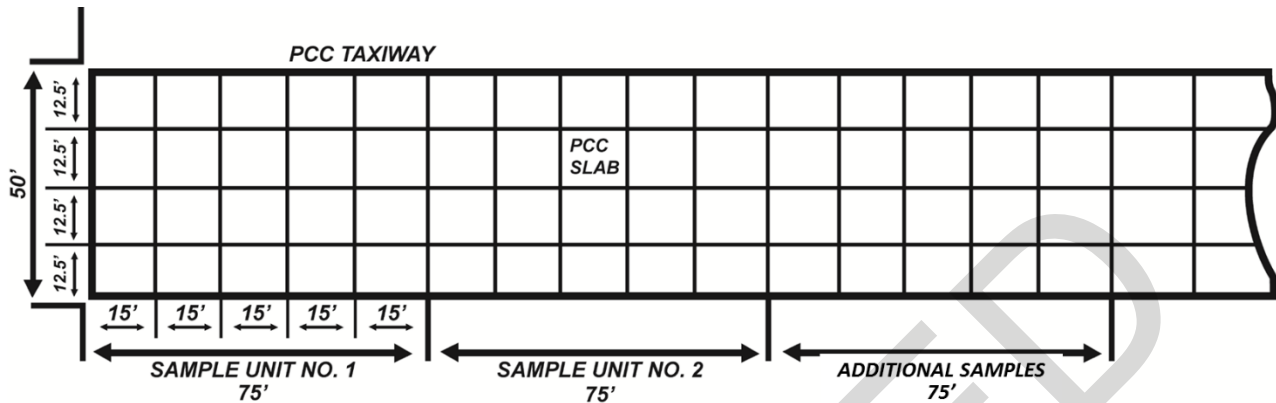
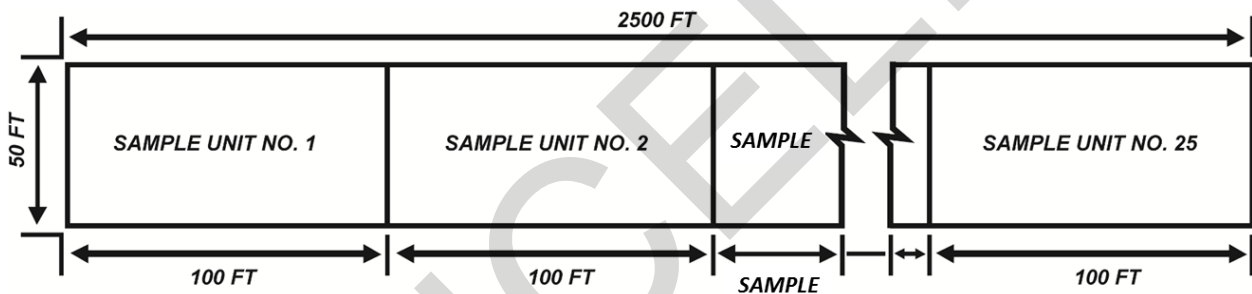

Figure 2-2 Example Division of a Flexible Pavement Section into Sample Units



SECTION DIMENSION = 50 X 2500 FT

SAMPLE UNIT = 50 X 100 FT

NUMBER OF SAMPLE UNITS = 25

2-3 NETWORK-LEVEL INSPECTION.

2-3.1 Determining the Number of Sample Units to be Inspected.

A network-level survey is conducted by surveying a few sample units per section. Table 2-1 provides an example of criteria used by some agencies for determining the number of sample units to survey at the network level. The number of units to be inspected (n) is increased by 1 for every increase of five units in section (N) until N equals 15. When N equals 16 to 40, the value of n is set at 4. When the value of N is greater than 40, n is set at 10 percent of N and rounded up to the next whole sample unit. For example, if $N = 52$ then $n = 6$ (rounded up from 5.2).

Table 2-1 Example of Network-Level Sampling Criteria Used by Some Agencies

No. of Sample Units in Section (<i>N</i>)	No. of Units to be Inspected (<i>n</i>)
1 to 5	1
6 to 10	2
11 to 15	3
16 to 40	4
Over 40	10 percent of <i>N</i> (round up to next whole sample unit)

2-3.2 Selecting Sample Units to Inspect.

When selecting sample units to inspect as recommended in Table 2-1, ensure the sample units are representative (not random) of the overall condition of the section. The main objective for budget estimating and network condition assessment is to obtain a meaningful rating with the least cost.

2-4 PROJECT-LEVEL INSPECTION.

2-4.1 Determining the Number of Sample Units to be Inspected.

Management at the project level requires accurate data for the preparation of work plans and contracts; therefore, more sample units are inspected than are usually sampled for network-level management. The first step in sampling is to determine the minimum number of sample units (*n*) to survey to obtain an adequate estimate of the section's PCI. This number is determined for a project-level evaluation by using the curves shown in Figure 2-3. Using this number, a reasonable estimate of the true mean PCI of the section is obtained. There is a 95 percent probability that the estimate is within ± 5 points of the true mean PCI (the PCI obtained if all the sample units were inspected).

The curves in Figure 2-3 were constructed using Equation 2-1:

Equation 2-1 Minimum Sample Units

$$n = \frac{N(s^2)}{\frac{e^2}{4}(N - 1) + s^2}$$

where:

n = minimum number of sample units

N = total number of sample units in the pavement section

e = allowable error in the estimate of the section PCI (The value *e* was set equal to 5 when constructing the curves of Figure 2-3.)

s = standard deviation of the PCI between sample units in the section

The curves in Figure 2-3 are based on the PCI standard deviation among sample units or PCI range (i.e., lowest sample unit PCI subtracted from the highest sample unit PCI). For the initial inspection, the PCI standard deviation for a pavement section is assumed to be 10 for asphalt concrete (AC)-surfaced pavements (or a PCI range of 25) and 15 for PCC-surfaced pavements (or a PCI range of 35). These values are based on field data obtained from many surveys; however, if local experience is different, use the average standard deviation reflecting local conditions for the initial inspection. For subsequent inspections, use the actual PCI standard deviation or range (determined from the previous inspection) to determine the minimum number of sample units to be surveyed. When the total number of samples within a section is less than five, survey all of the sample units.

Figure 2-3 Selection of the Minimum Number of Sample Units¹

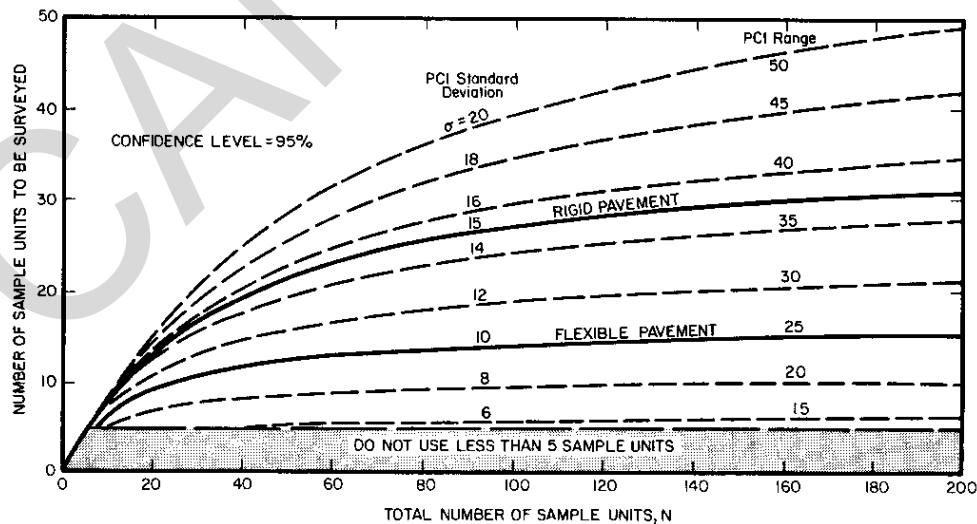

¹ Shahin et al., 1976-1977

2-4.2 Selecting Sample Units to Inspect.

Space the sample units to be inspected equally throughout the section, with the first unit chosen at random. This technique, known as “systematic random,” is illustrated in Figure 2-4 and described by the following three steps:

1. The sample interval (i) is determined by $i = N \div n$, where N equals the total number of available sample units and n equals the minimum number of sample units to be surveyed. The sampling interval (i) is rounded to the smaller whole number (for example, 3.6 is rounded to 3.0).
2. Random starts are selected between sample unit 1 and the sampling interval (i). For example, if $i = 3$, the random start would be a number from 1 to 3.
3. The sample units to be surveyed are identified as S , $S+i$, $S+2i$, and so forth. If the selected start is 3 and the sampling interval is 3 then the sample units to be surveyed are 3, 6, 9, 12, and so forth.

Figure 2-4 Example of Systematic Random Sampling

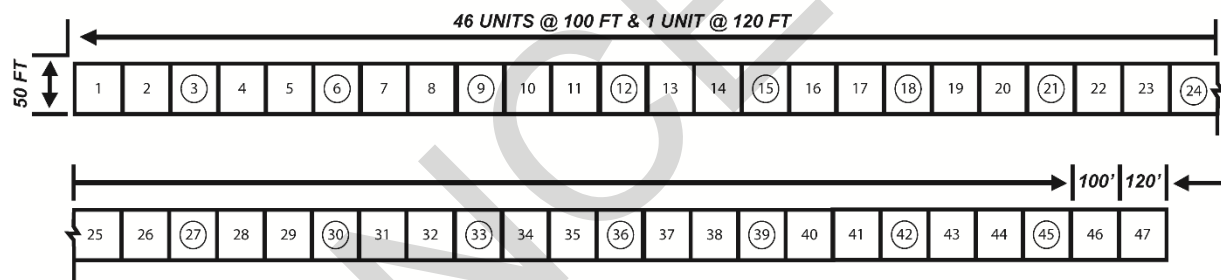

TOTAL NUMBER OF SAMPLE UNITS IN SECTION (N)	= 47
MINIMUM NUMBER OF UNITS TO BE SURVEYED (n)	= 13
INTERVAL (i) = $N / n = 47 / 13 = 3.6$	= 3
RANDOM START (S)	= 3

2-5 SELECTION OF ADDITIONAL SAMPLE UNITS.

One of the major drawbacks to both systematic random sampling at the project level and representative sampling at the network level is that sample units in exceptionally bad condition may not necessarily be included in the survey. At the same time, sample units that have a one-time-occurrence type of distress (for example, utility cut patching) may be included inappropriately as a random sample.

To overcome these drawbacks, identify any unusual sample units and inspect them as additional units rather than as random or representative units. When additional sample units are included in the survey, the calculation of the section PCI is altered to prevent

extrapolation of the unusual conditions across the entire section. This procedure is described in more detail in Chapter 3.

2-6 PAVEMENT DISTRESS RECORDING.

2-6.1 Example PCI Survey Sheets: Airfield Pavements.

Figures 2-5 and 2-6 are sample PCI survey sheets. Blank forms are in Appendix E.

CANCELLED

Figure 2-6 Concrete-Surfaced Airfield Pavements Example PCI Survey Sheet

PCC AIRFIELD PAVEMENT CONDITION SURVEY DATA SHEET (Automated)				
PID Delta_R1230_B03		INSPECTOR S. Smith NAME		
FROM TW F		BRANCH USE Runway		DATE INSPECTED 06/20/2018
To RW 30 END		SECTION WIDTH 100 FT		SECTION LENGTH 2000 FT
SLAB WIDTH 25 FT	SLAB LENGTH 25 FT	NUMBER OF 320 SLABS		
PCC Surfaced Distress Codes				
61. Blowup {1}	65. Joint Seal Damage {5}	69. Pumping {9}	73. Shrinkage Cracks {13}	
62. Corner Break {2}	66. Patching, Small < 1.5 m (< 5 ft) {6}	70. Scaling {10}	74. Spalling, Joints {14}	
63. Cracks {3}	67. Patching, Large/ Utility Cut {7}	71. Settlement/Faulting {11}	75. Spalling, Corner {15}	
64. Durability Cracking {4}	68. Popouts {8}	72. Shattered Slab {12}	76. ASR {16}	
SAMPLE NUMBER 005		SLABS IN SAMPLE 20		SKETCH/COMMENTS
DISTRESS CODE	L	M	H	
63	5	2		
74	3			
72	1			
75	6			

CHAPTER 3 PCI CALCULATION PROCEDURE

3-1 INTRODUCTION.

The PCI is calculated for each inspected sample unit. The PCI cannot be computed for the entire pavement section without computing the PCI for the sample units first. The PCI calculation is based on the deduct values, which are weighting factors from 0 to 100 that indicate the impact each distress has on pavement condition. A deduct value of 0 indicates that a distress has no effect on either pavement structural integrity or surface operational condition, whereas a value of 100 indicates an extremely serious distress.

3-2 CALCULATION OF A SAMPLE UNIT PCI FOR ASPHALT-SURFACED PAVEMENTS.

The PCI calculation procedure is illustrated for the sample unit example shown in Figure 3-1. The calculation steps are summarized in Figure 3-2 and paragraphs 3-2.1 through 3-2.4.

CANCELLED

Figure 3-2 PCI Calculation Steps for Sample Unit

STEP 1: DETERMINE DEDUCT VALUES

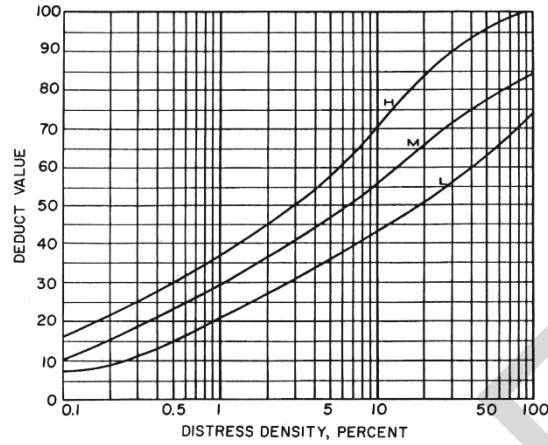

STEP 2: DETERMINE MAXIMUM ALLOWABLE NUMBER OF DEDUCTS (m)

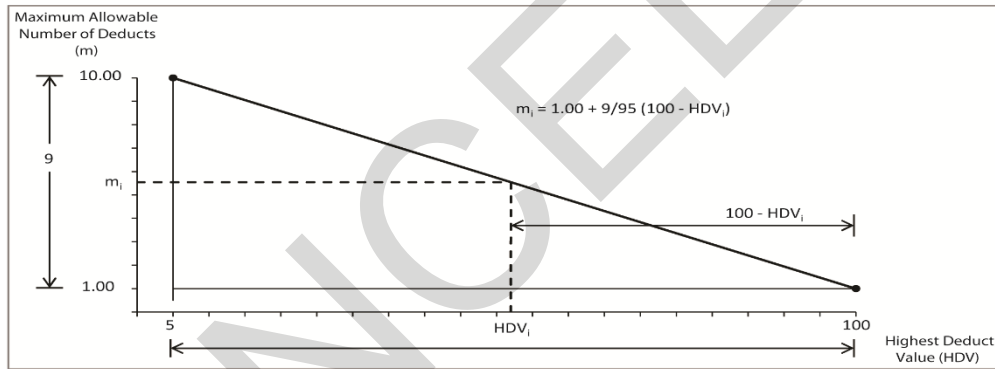

STEP 3: DETERMINE MAXIMUM CORRECTED DEDUCT VALUE

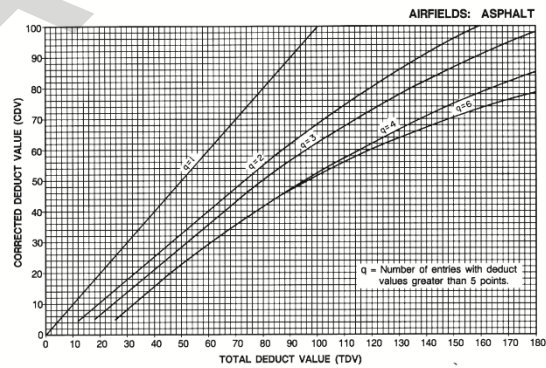

STEP 4: CALCULATE PCI

$PCI = 100 - \text{MAXIMUM CDV}$

3-2.1 Step 1: Determine Deduct Values.

Table 3-1 shows the results of the calculation of the deduct values for the distresses shown in Figure 3-1.

- 1a. Add the totals for each distress type at each severity level and record them as shown in Table 3-1. Distress quantities are measured in square feet (square meters), linear feet (meters), or number of occurrences, depending on the distress type.
- 1b. Divide the quantity of each distress type at each severity level by the total area of the sample unit then multiply by 100 to obtain the percentage of density per sample unit for each distress type and severity.
- 1c. Determine the deduct value for each distress type and severity level combination from the distress deduct value curves. Figure 3-3 shows an example of a deduct curve for distress type 41, alligator cracking, for asphalt-surfaced airfield pavements. Deduct curves for all asphalt airfield distresses are provided in Appendix C.

Table 3-1 Calculation of Deduct Values for Distresses Shown in Figure 3-1

Paver Distress	ASTM Distress	Description	Severity	Qty (ft/ft ²)	Qty (m/m ²)	Density	Deduct
(41)	{1}	Alligator cracking	L	53 ft ²	4.9 m ²	1.06	21.0
(45)	{5}	Depression	L	75 ft ²	7.0 m ²	1.5	9.2
(48)	{8}	Longitudinal and transverse cracking	L	47 ft	14.3 m	0.94	4.8
(48)	{8}	Longitudinal and transverse cracking	M	16 ft	4.9 m	0.32	6.7
(53)	{13}	Rutting	M	25 ft ²	2.3 m ²	0.5	20.2

ft² (m²) = square feet (square meters)
ft (m) = feet (meters)

Figure 3-3 AC Pavement Deduct Curve for Alligator Cracking Distress

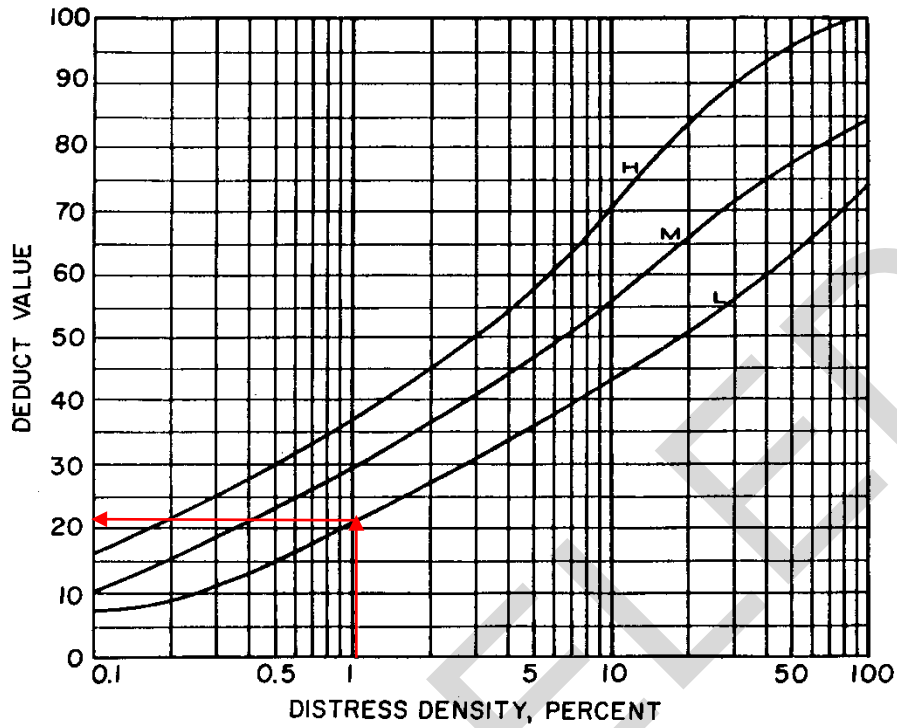

3-2.2 Step 2: Determine the Maximum Allowable Number of Deducts (m).

The maximum allowable number of deducts is calculated as shown in Figure 3-4 or using Equation 3-1.

Figure 3-4 Determination of Maximum Allowable Deducts (m) for Airfield Pavements

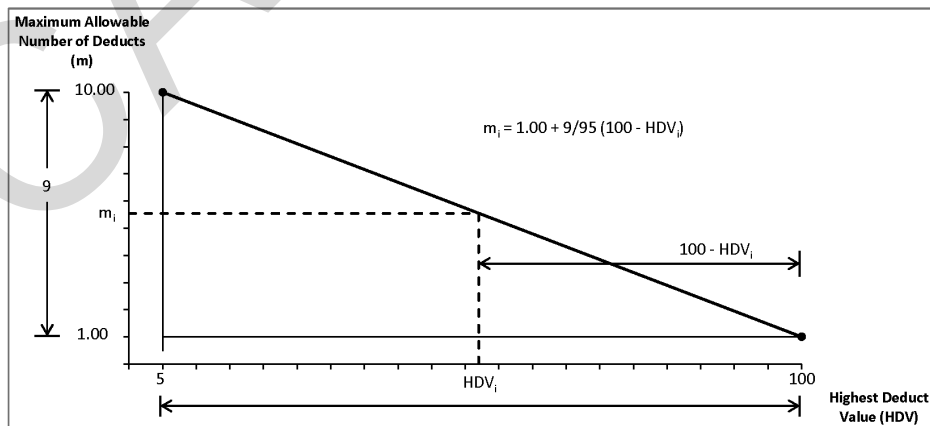

Equation 3-1 Allowable Number of Deducts for Airfields

$$m_i = 1 + \left(\frac{9}{95}\right)(100 - HDV_i)$$

where:

m_i = allowable number of deducts, including fractions, for sample unit i

HDV_i = highest individual deduct value for sample unit i

For example, in Table 3-1 (calculated from Figure 3-1) the allowable number of deducts is calculated as:

$$m_i = 1 + \left(\frac{9}{95}\right)(100 - 21.02) = 8.48$$

The number of individual deduct values is reduced to m , including the fractional part. If fewer than m deduct values are available then all the deduct values are used. For the example in Figure 3-1, all the deduct values are used since they are less than m .

3-2.3 Step 3: Determine the Maximum Corrected Deduct Value (CDV).

The maximum CDV is determined iteratively as described in these five steps:

- 3a. List the individual deduct values in descending order as shown in Figure 3-5, row 1. For example, the values in Table 3-1, which were calculated from the example shown in Figure 3-1, are sorted as follows: 21, 20.2, 9.2, 6.7, and 4.8.
- 3b. Determine the total deduct value by adding all individual deduct values. In the current example, the total deduct value is 61.9.
- 3c. Determine the CDV from q (number of deduct values over 5) and the total deduct value by looking up the appropriate correction curve. Figure 3-6 shows the correction curve for asphalt-surfaced airfield pavements. The CDV for row 1 is calculated as 31.
- 3d. Reduce to 5.0 the smallest individual deduct value that is greater than 5.0, as shown in row number 2 in Figure 3-5. Repeat steps 3b and 3c until q is equal to 1.
- 3e. The maximum CDV is the largest of the CDVs determined.

Figure 3-5 PCI Calculation Sheet for Example Sample Unit Shown in Figure 3-1

AC $m = 8.48 > 5$

PCI CALCULATION FORM												
BRANCH Runway				SECTION B01				SAMPLE UNIT 008				
CALCULATED BY S. Smith				DATE 06/20/2018								
Adjustment of the Number of Deduct Values (1 Minimum, 10 Maximum):												
ITERATION NUMBER	DEDUCT VALUES (Arrange Values from Highest Value to Lowest Value)								DEDUCT TOTAL	Number of Deduct Values Greater than (but not equal to) 5.0 q	Corrected Deduct Value CDV	
	* Do not list more values than the Adjustment Number of Deduct Values (round to the next higher integer if a fraction/decimal)											
	** The last (lowest) value listed may be a fraction of one of the DEDUCT VALUES in the Condition Survey Data Sheet											
1	21.0	20.2	9.2	6.7	4.8					61.9	4	31
2	21.0	20.2	9.2	5.0	4.8					60.2	3	36
3	21.0	20.2	5.0	5.0	4.8					56.0	2	37
4	21.0	5.0	5.0	5.0	4.8					40.8	1	41
5												
6												
7												
8												
9												
10												
MAXIMUM CDV = 41												
Corrected Pavement Condition Index (PCI) = 100 - MAXIMUM CDV = 59												

Figure 3-6 Correction Curves for AC-Surfaced Airfield Pavements

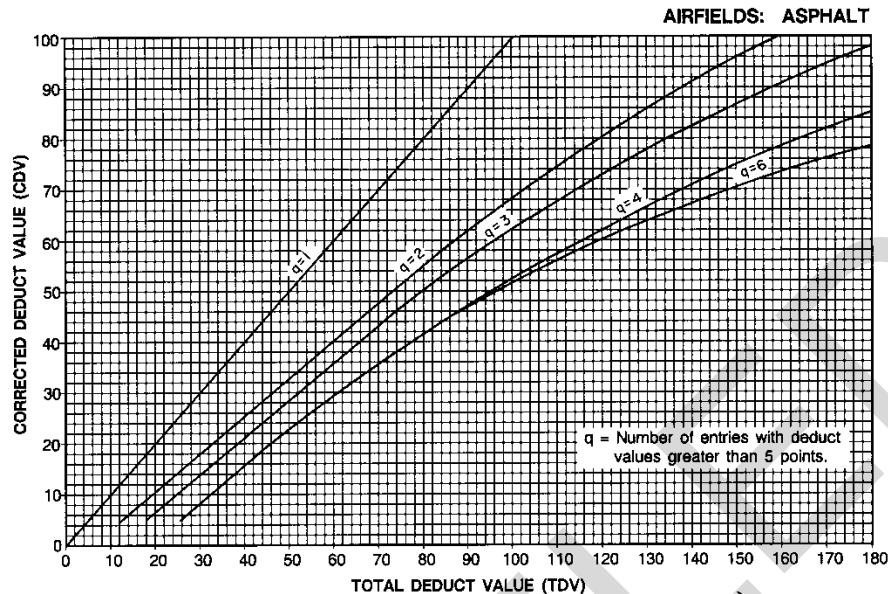

3-2.4 Step 4: Calculate PCI by Subtracting the Maximum CDV from 100.

For the example, the PCI equals $100 - 41 = 59$.

3-3 CALCULATION OF A SAMPLE UNIT PCI FOR CONCRETE-SURFACED PAVEMENTS.

3-3.1 Step 1: Determine Deduct Values.

Table 3-2 shows the results of the calculation of the deduct values for the distresses shown in Figure 3-7.

- 1a. For each unique combination of distress type and severity level, add the number of slabs in which they occur. For example, Figure 3-7 lists three slabs with low-severity joint spalling.
- 1b. Divide the number of slabs from step 1a by the total number of slabs in the sample unit then multiply by 100 to obtain the percentage of density per sample unit for each distress type and severity combination.
- 1c. Determine the deduct values for each distress type and severity level combination using the appropriate deduct curve in Appendix D for concrete airfields.

Figure 3-7 Concrete-Surfaced Airfield PCI Survey Data Sheet Example

PCC AIRFIELD PAVEMENT CONDITION SURVEY DATA SHEET (Automated)				
PID Delta_R1230_B03		INSPECTOR S. Smith NAME		
FROM TW F		BRANCH USE Runway		DATE INSPECTED 06/20/2018
TO RW 30 END		SECTION WIDTH 100 FT		SECTION LENGTH 2000 FT
SLAB WIDTH 25 FT	SLAB LENGTH 25 FT	NUMBER OF 320 SLABS		
PCC Surfaced Distress Codes				
61. Blowup {1}	65. Joint Seal Damage {5}	69. Pumping {9}	73. Shrinkage Cracks {13}	
62. Corner Break {2}	66. Patching, Small < 1.5 m (< 5 ft) {6}	70. Scaling {10}	74. Spalling, Joints {14}	
63. Cracks {3}	67. Patching, Large/ Utility Cut {7}	71. Settlement/Faulting {11}	75. Spalling, Corner {15}	
64. Durability Cracking {4}	68. Popouts {8}	72. Shattered Slab {12}	76. ASR {16}	
SAMPLE NUMBER 005		SLABS IN SAMPLE 20		SKETCH/COMMENTS
DISTRESS CODE	L	M	H	
63	5	2		
74	3			
72	1			
75	6			

Table 3-2 Calculation of Deduct Values for Distresses Shown in Figure 3-7

Paver Distress	ASTM Distress	Description	Severity	Quantity	Units	Density	Deduct
(63)	{4}	Linear cracking	M	2	Slabs	10	18.7
(63)	{4}	Linear cracking	L	5	Slabs	25	15.4
(72)	{13}	Shattered slab	L	1	Slabs	5	11.0
(74)	{15}	Joint spall	L	3	Slabs	15	4.8
(75)	{16}	Corner spall	L	6	Slabs	30	9.6

3-3.2 Step 2: Determine the Maximum Allowable Number of Deducts (m).

This step is the same as the comparable step for asphalt-surfaced pavements described in paragraph 3-2.2. For the example in Figure 3-7, based on a highest deduct value (HDV) of 18.66, m is calculated using Equation 3-1:

$$m_i = 1 + \left(\frac{9}{95}\right) (100 - 18.66) = 8.71$$

The maximum allowable number of deducts, m , was calculated to be 8.71. There are only five deduct values (18.66, 15.43, 11.02, 4.78, and 9.62) so taking a percentage of one of the deduct values is not necessary; however, if in the sample unit m was calculated to be 3.4, it would be necessary to take the three highest deduct values and 40 percent of the fourth-highest deduct value.

3-3.3 Step 3: Determine the Maximum CDV.

Determine the maximum CDV by following the procedures in paragraph 3-2.3 but using the appropriate correction curve in Appendix D for concrete airfields.

3-3.4 Step 4: Calculate the PCI by Subtracting the Maximum CDV from 100.

Figure 3-8 summarizes the PCI calculation for the example of PCC pavement data shown in Figure 3-7.

Figure 3-8 PCI Calculation Sheet for the Example Sample Unit
Shown in Figure 3-7

PCC $m = 8.8 > 5$

PCI CALCULATION FORM												
BRANCH Runway				SECTION B03				SAMPLE UNIT 005				
CALCULATED BY S. Smith				DATE 06/20/2018								
Adjustment of the Number of Deduct Values (1 Minimum, 10 Maximum):												
ITERATION NUMBER	DEDUCT VALUES (Arrange Values from Highest Value to Lowest Value)								DEDUCT TOTAL	Number of Deduct Values Greater than (but not equal to) 5.0 q	Corrected Deduct Value CDV	
	* Do not list more values than the Adjustment Number of Deduct Values (round to the next higher integer if a fraction/decimal)											
** The last (lowest) value listed may be a fraction of one of the DEDUCT VALUES in the Condition Survey Data Sheet												
1	18.7	15.4	11.0	9.6	4.8					59.5	4	38
2	18.7	15.4	11.0	5.0	4.8					54.9	3	38
3	18.7	15.4	5.0	5.0	4.8					48.9	2	42
4	18.7	5.0	5.0	5.0	4.8					38.5	1	38
5												
6												
7												
8												
9												
10												
MAXIMUM CDV = 42												
Corrected Pavement Condition Index (PCI) = 100 - MAXIMUM CDV = 58												

3-4 CALCULATION OF THE PCI FOR A PAVEMENT SECTION.

If all surveyed sample units are selected either by using the systematic random technique or on the basis of being representative of the section and are equal in size, the PCI of the section is determined by averaging the PCIs of the inspected sample units. If the inspected sample units are not equal in size, use area-weighted averaging as shown in Equation 3-2.

Equation 3-2 Area Weighted Averaging for Unequally Sized Sample Units

$$PCI_s = PCI_r = \frac{\sum_{i=1}^R (PCI_{ri} A_{ri})}{\sum_{i=1}^R A_{ri}}$$

where:

PCI_s = PCI of pavement section

PCI_r = area-weighted average PCI of random (or representative) sample units

PCI_{ri} = PCI of random sample unit number i

A_{ri} = area of the random sample unit i

R = total number of inspected random sample units

If additional sample units are inspected in addition to the random or representative units, the section PCI is computed using Equations 3-3 and 3-4:

Equation 3-3 Area Weighted Average PCI for Additional Sample Units

$$PCI_a = \frac{\sum_{i=1}^A (PCI_{ai} \times A_{ai})}{\sum_{i=1}^A (A_{ai})}$$

Equation 3-4 Section PCI for Additional Sample Units

$$PCI_s = \frac{PCI_r (A_s - \sum_{i=1}^A A_{ai}) + PCI_a \times \sum_{i=1}^A A_{ai}}{A_s}$$

where:

PCI_a = area weighted average PCI of additional sample units

PCI_{ai} = PCI of additional sample unit number i

A_{ai} = area of additional sample unit i

A_s = total section area

For example, if in a section of 60,000 square feet (5,574 square meters), five random sample units were inspected and determined to have PCIs of 56 (5,000 square feet [465 square meters]), 72 (5,000 square feet [465 square meters]), 65 (5,000 square feet [465 square meters]), 69 (4,000 square feet [372 square meters]), and 61 (4,000 square feet [372 square meters]), and two additional sample units with PCIs of 42 (3,500 square feet [325 square meters]) and 39 (3,500 square feet [325 square meters]) were included, the PCI of the section would be:

$$PCI_r = \frac{(56 \times 5,000) + (72 \times 5,000) + (65 \times 5,000) + (69 \times 4,000) + (61 \times 4,000)}{5,000 + 5,000 + 5,000 + 4,000 + 4,000}$$
$$PCI_r = 64.57$$

$$PCI_a = \frac{(42 \times 3,500) + (39 \times 3,500)}{3,500 + 3,500}$$
$$PCI_a = 40.5$$

$$PCI_s = \frac{64.57(60,000 - 7,000) + 40.5 \times 6,500}{60,000}$$
$$PCI_s = 61$$

3-5 EXTRAPOLATING DISTRESS QUANTITIES FOR A PAVEMENT SECTION.

3-5.1 When a pavement has been inspected by sampling, it is necessary to extrapolate the quantities and densities of distress over the entire pavement section to determine total quantities for the section. If all sample units surveyed were selected at random, the extrapolated quantity of a given distress at a given severity level is determined as shown in the following example for an asphalt-surfaced airfield with medium-severity alligator cracking:

Surface type: AC

Section area: 49,000 square feet (4,552 square meters)

Total number of sample units in section: 10

3-5.2 Five sample units were surveyed at random and the amount of medium-severity alligator cracking was determined as shown in Table 3-3:

Table 3-3 Medium-Severity Alligator Cracking in Five Surveyed Sample Units

Sample Unit ID Number	Sample Unit Area ft ² (m ²)	Medium-Severity Alligator Cracking ft ² (m ²)
02	5,000 (465)	200 (18.6)
04	5,000 (465)	400 (37.2)
06	5,000 (465)	300 (27.9)
08	5,000 (465)	100 (9.3)
10	4,000 (372)	200 (18.6)
Total Random	24,000 (2230)	1,200 (111.5)

3-5.3 The average density for medium-severity alligator cracking then is 1,200 divided by 24,000, or 0.05. The extrapolated quantity is determined by multiplying density by section area ($0.05 \times 49,000 = 2,450$ square feet [227.6 square meters]). If additional sample units were included in the survey, the extrapolation process is slightly different. In the above example, assume that sample unit number 01 was surveyed as an additional unit and that the amount of medium-severity alligator cracking was measured as shown in Table 3-4:

Table 3-4 Medium-Severity Alligator Cracking in an Additional Sample Unit

Additional Sample Unit ID Number	Sample Unit Area ft ² (m ²)	Medium-Severity Alligator Cracking ft ² (m ²)
01	5,000 (465)	2,000 (186)
Total Additional	5,000 (465)	2,000 (186)

3-5.4 Since 5,000 square feet (465 square meters) were surveyed as additional in this example, the section's randomly represented area is 49,000 - 5,000 square feet (4,552 - 465 square meters) or 44,000 square feet (4087 square meters). The extrapolated distress quantity is obtained by multiplying the distress density by the section's randomly represented area then adding the amount of additional distress. In this example, the extrapolated distress quantity equals ($0.05 \times 44,000$ square feet (4,087 square meters) + 2,000 square feet (186 square meters) or 4,200 square feet (390 square meters).

APPENDIX A DISTRESS DEFINITIONS - ASPHALT-SURFACED AIRFIELDS.

A-1 INTRODUCTION.

This appendix contains distress definitions and measurement methods for asphalt-surfaced airfields. This information is used to determine the PCI.

Note: Each distress definition is followed by a number in parentheses, indicating the PAVER distress code, and a number in braces, indicating the ASTM D5340 distress code, i.e.,

“Distress (#) {#}.” See Table 3-5.

Table A-1 Frequently Occurring Problems in Asphalt Pavement Distress Identification

Situation	Action	Remarks
Alligator cracking and rutting in same area	Record each separately at respective severity level	
Bleeding counted in area	Polished aggregate is not counted in same area	
Polished aggregate in very small amount	Do not count	Polished aggregate is only counted when there is a significant amount
Any distress (including cracking) in a patched area	Do not record	Effect of distress is considered in patch severity level
Block cracking is recorded	For asphalt pavements, not including AC over PCC, if block cracking is recorded, do not record longitudinal and transverse cracking in the same area	
Asphalt overlay over concrete	Block cracking and joint reflection cracking are recorded separately	AC over PCC could have, for example, 100 percent block cracking and 100 feet of joint reflection cracking
Weathering (surface wear) and raveling in the same sample area	Weathering (surface wear) is not recorded if medium- or high-severity raveling is recorded	Raveling is always recorded

A-2 ALLIGATOR (FATIGUE) CRACKING (41) {1}.

A-2.1 Description.

Alligator (or fatigue) cracking is a series of interconnecting cracks caused by fatigue failure of the asphalt surface under repeated traffic loading. The cracking initiates at the bottom of the asphalt surface (or stabilized base) where tensile stress and strain is highest under a wheel load. The cracks propagate to the surface initially as a series of parallel cracks. After repeated traffic loading, the cracks connect and form multi-sided, sharp-angled pieces that develop a pattern resembling chicken wire or the skin of an alligator. The pieces are less than 2 feet (0.6 meter) on the longest side. Alligator cracking occurs only in areas subjected to repeated traffic loadings, such as wheel paths; therefore, it would not occur over an entire area unless the entire area was subjected to traffic loading. (Pattern-type cracking that occurs over an entire area that is not subject to loading is rated as block cracking, which is not a load-associated distress.) Alligator cracking is considered a major structural distress.

A-2.2 Severity Levels.

L Fine, longitudinal hairline cracks running parallel to each other with no or only a few interconnecting cracks. The cracks are not spalled.

M Further development of light alligator cracking into a pattern or network of cracks that may be lightly spalled. Medium-severity alligator cracking is defined by a well-defined pattern of interconnecting cracks, where all pieces are securely held in place (i.e., good aggregate interlock between pieces).

H Network or pattern cracking progresses so that pieces are well-defined and spalled at the edges; some of the pieces rock under traffic and may cause foreign object damage (FOD) potential.

A-2.3 How to Measure.

Alligator cracking is measured in square feet (square meters) of surface area. The major difficulty in measuring this type of distress is that often two or three levels of severity exist within one distressed area. If these portions can be easily distinguished from each other, measure and record separately; however, if the different levels of severity cannot be easily divided, rate the entire area at the highest severity level present. If alligator cracking and rutting occur in the same area, each is recorded separately at its respective severity level.

Figure A-1 Low-Severity Alligator Cracking



Figure A-2 Medium-Severity Alligator Cracking



Figure A-3 High-Severity Alligator Cracking



A-3 BLEEDING (42) {2}.

A-3.1 Description.

Bleeding is a film of bituminous material on the pavement surface that creates a shiny, glass-like, reflecting surface that usually becomes quite sticky. Bleeding is caused by excessive amounts of asphalt cement or tars in the mix and/or low air-void content. Bleeding occurs when asphalt fills the voids of the mix during hot weather and then expands onto the surface of the pavement. Since the bleeding process is not reversible during cold weather, asphalt or tar will accumulate on the surface.

A-3.2 Severity Levels.

No degrees of severity are defined. Note bleeding when it is extensive enough to cause a reduction in skid resistance.

A-3.3 How to Measure.

Bleeding is measured in square feet (square meters) of surface area. If bleeding is counted, polished aggregate is not counted in the same area.

Figure A-4 Bleeding



Figure A-5 Bleeding



A-4 BLOCK CRACKING (43) {3}.

A-4.1 Description.

Block cracks are interconnected cracks that divide the pavement into roughly rectangular pieces. The blocks may range in size from approximately 1 by 1 foot to 10 by 10 feet (0.3 by 0.3 meter to 3 by 3 meters). Block cracking is caused mainly by shrinkage of the AC and daily temperature cycling (which results in daily stress/strain cycling); it is not load-associated. The occurrence of block cracking usually indicates that the asphalt has significantly hardened. Block cracking typically occurs over a large proportion of pavement area but sometimes will occur in non-traffic areas. This type of distress differs from alligator cracking in that alligator cracks form smaller, multi-sided pieces with sharp angles. Also, unlike block cracks, alligator cracks are caused by repeated traffic loadings and therefore are located only in traffic areas (i.e., wheel paths).

A-4.2 Severity Levels.

L Blocks are defined by cracks that are non-spalled (sides of the crack are vertical) or only lightly spalled, causing no FOD potential. Non-filled cracks have 0.25 inch (6 millimeters) or less mean width and filled cracks have filler in satisfactory condition.

M Blocks are defined by either (1) filled or non-filled cracks that are moderately spalled (some FOD potential); (2) non-filled cracks that are not spalled or have only

minor spalling (some FOD potential) but have a mean width greater than approximately 0.25 inch (6 millimeters); or (3) filled cracks that are not spalled or have only minor spalling (some FOD potential) but have filler in unsatisfactory condition.

H Blocks are well defined by cracks that are severely spalled, causing a definite FOD potential.

A-4.3 How to Measure.

Block cracking is measured in square feet (square meters) of surface area. It usually occurs at one severity level in a given pavement section; however, measure and record separately any areas of the pavement section having distinctly different levels of severity. For asphalt pavements, not including AC over PCC, if block cracking is recorded, do not record longitudinal and transverse (L&T) cracking in the same area. For asphalt overlay over concrete, separately record block cracking, joint reflection cracking, and L&T cracking reflected from old concrete.

Figure A-6 Low-Severity Block Cracking



Figure A-7 Low-Severity Block Cracking



Figure A-8 Medium-Severity Block Cracking



Figure A-9 Medium-Severity Block Cracking



Figure A-10 High-Severity Block Cracking



Figure A-11 High-Severity Block Cracking



A-5 CORRUGATION (44) {4}.

A-5.1 Description.

Corrugation is a series of closely spaced ridges and valleys (ripples) occurring at fairly regular intervals, usually less than 5 feet (1.5 meters) along the pavement. The ridges are perpendicular to the traffic direction. Traffic action combined with an unstable pavement surface or base usually causes this type of distress.

A-5.2 Severity Levels.

L Corrugations are minor and do not significantly affect ride quality (see measurement criteria below).

M Corrugations are noticeable and significantly affect ride quality (see measurement criteria below).

H Corrugations are easily noticed and severely affect ride quality (see measurement criteria below).

A-5.3 How to Measure.

Corrugation is measured in square feet (square meters) of surface area. The mean elevation difference between the ridges and valleys of the corrugations indicates the level of severity. To determine the mean elevation difference, place a 10-foot (3-meter) straightedge perpendicular to the corrugations so the depth of the valleys is measured in inches (millimeters). The mean depth is calculated from five such measurements. See Table A-2 and Figure A-12.

Table A-2 Corrugation Measurement Criteria

Measurement Criteria Severity	Runways and High-Speed Taxiways	Taxiways and Aprons
L	< 0.25 inch (< 6 mm)	< 0.5 inch (< 13 mm)
M	0.25 to 0.5 inch (6 to 13 mm)	0.5 to 1 inch (13 to 25 mm)
H	> 0.5 inch (> 13 mm)	> 1 inch (> 25 mm)

Figure A-12 Corrugation

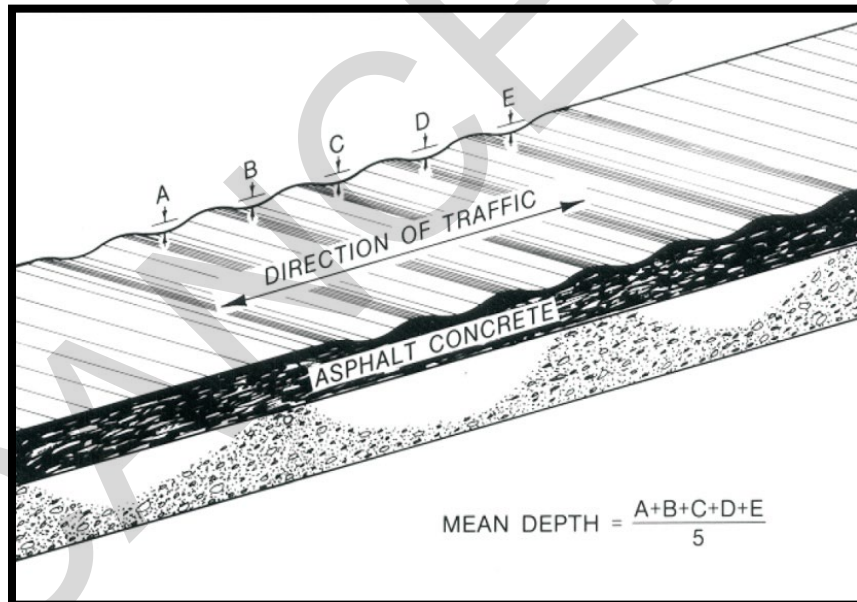

Figure A-13 Low-Severity Corrugation



Figure A-14 Medium-Severity Corrugation



Figure A-15 High-Severity Corrugation



A-6 DEPRESSION (45) {5}.

A-6.1 Description.

Depressions are localized pavement surface areas having elevations slightly lower than those of the surrounding pavement. In many instances, light depressions are not noticeable until after a rain, when ponding water creates “birdbath” areas, but the depressions can also be located without rain because of stains created by ponding water. Depressions can be caused by settlement of the foundation soil or can be built up during construction. Depressions cause roughness and, when filled with water of sufficient depth, can cause hydroplaning of aircraft.

A-6.2 Severity Levels.

L Depression can be observed or located by stained areas, only slightly affects pavement riding quality, and may cause hydroplaning potential on runways (see measurement criteria below).

M Depression can be observed, moderately affects pavement riding quality, and causes hydroplaning potential on runways (see measurement criteria below).

H Depression can be readily observed, severely affects pavement riding quality, and causes definite hydroplaning potential (see measurement criteria below).

A-6.3 How to Measure.

Depressions are measured in square feet (square meters) of surface area. The maximum depth of the depression determines the level of severity. This depth can be measured by placing a 10-foot (3-meter) straightedge across the depressed area and measuring the maximum depth in inches (millimeters). Depressions larger than 10 feet (3 meters) across must be measured by either visual estimation or direct measurement when filled with water.

Table A-3 Maximum Depth of Depression

Severity	Runways & High-Speed Taxiways	Taxiways & Aprons
L	0.125 to 0.5 in (3 to 13 mm)	0.5 to 1 inch (13 to 25 mm)
M	0.5 to 1 inch (13 to 25 mm)	1 to 2 inches (25 to 51 mm)
H	> 1 inch (> 25 mm)	> 2 inches (> 51 mm)

Figure A-16 Low-Severity Depression



Figure A-17 Medium-Severity Depression



Figure A-18 High-Severity Depression



Figure A-19 High-Severity Depression



A-7 JET BLAST EROSION (46) {6}.

A-7.1 Description.

Jet blast erosion causes darkened areas on the pavement surface when bituminous binder has been burned or carbonized; localized burned areas may vary in depth up to approximately 0.5 inch (13 millimeters).

A-7.2 Severity Levels.

No degrees of severity are defined. It is sufficient to indicate that jet blast erosion exists.

A-7.3 How to Measure.

Jet blast erosion is measured in square feet (square meters) of surface area.

Figure A-20 Jet Blast Erosion



A-8 JOINT REFLECTION CRACKING FROM PCC (47) {7}.

A-8.1 Description.

This distress occurs only on pavements having an asphalt or tar surface over a PCC slab. This category does not include reflection cracking from any other type of base (i.e., cement stabilized, lime stabilized); such cracks are listed as L&T cracks. Joint reflection cracking is caused mainly by movement of the PCC slab beneath the AC surface because of thermal and moisture changes; it is not load-related. However, traffic loading may cause a breakdown of the AC near the crack, resulting in spalling and FOD potential. If the pavement is fragmented along a crack, the crack is said to be spalled. Knowledge of the slab dimensions beneath the AC surface will help identify these cracks.

A-8.2 Severity Levels.

L Cracks have only light spalling (little or no FOD potential) or no spalling and can be filled or non-filled. If non-filled, the cracks have a mean width of 0.25 inch (6 millimeters) or less. Filled cracks are of any width but their filler material is in satisfactory condition.

M One of these conditions exists: (1) cracks are moderately spalled (some FOD potential) and can be either filled or non-filled of any width; (2) filled cracks are not spalled or are only lightly spalled but the filler is in unsatisfactory condition; (3) non-filled cracks are not spalled or are only lightly spalled but the mean crack width is greater than 0.25 inch (6 millimeters); or (4) light random cracking exists near the crack or at the corner of intersecting cracks.

H Cracks are severely spalled (definite FOD potential) and can be either filled or non-filled of any width.

A-8.3 How to Measure.

Joint reflection cracking is measured in linear feet (linear meters). Identify and record the length and severity level of each crack. If the crack does not have the same severity level along its entire length, separately record each portion. For example, a crack that is 50 feet (15 meters) long may have 10 feet (3 meters) of high-severity cracking, 20 feet (6 meters) of medium-severity cracking, and 20 feet (6 meters) of low-severity cracking; these are recorded separately. If the different levels of severity in a portion of a crack cannot be easily divided, rate that portion at the highest severity present.

Figure A-21 Low-Severity Joint Reflection Cracking



Figure A-22 Medium-Severity Joint Reflection Cracking



Figure A-23 High-Severity Joint Reflection Cracking



**A-9 LONGITUDINAL AND TRANSVERSE (L&T) CRACKING (48) {8}
(NON-PCC JOINT REFLECTIVE).**

A-9.1 Description.

Longitudinal cracks are parallel to the pavement's centerline or laydown direction. They may be caused by (1) a poorly constructed paving lane joint, (2) shrinkage of the AC surface due to low temperatures or hardening of the asphalt, or (3) a reflective crack caused by cracks beneath the surface course, including cracks in PCC slabs (but not at PCC joints). Transverse cracks extend across the pavement at approximately right angles to the pavement centerline or direction of laydown. They may be caused by items 2 or 3 above. These types of cracks are not usually load-associated. If the pavement is fragmented along a crack, the crack is said to be spalled.

A-9.2 Severity Levels.

L Cracks have either minor spalling (little or no FOD potential) or no spalling. The cracks can be filled or non-filled. Non-filled cracks have a mean width of 0.25 inch (6 millimeters) or less; filled cracks are of any width but their filler material is in satisfactory condition.

M One of these conditions exists: (1) cracks are moderately spalled (some FOD potential) and can be either filled or non-filled of any width; (2) filled cracks are not spalled or are only lightly spalled but the filler is in unsatisfactory condition; (3) non-filled cracks are not spalled or are only lightly spalled but the mean crack width is greater than 0.25 inch (6 millimeters); or (4) light random cracking exists near the crack or at the corners of intersecting cracks.

H Cracks are severely spalled, causing definite FOD potential. They can be either filled or non-filled of any width.

A-9.3 How to Measure.

L&T cracks are measured in linear feet (linear meters). Identify and record the length and severity of each crack. If the crack does not have the same severity level along its entire length, separately record each portion of the crack with a different severity level. For example, see the explanation of how to measure joint reflection cracking in paragraph A-8.3. If block cracking is recorded, L&T cracking are not recorded in the same area.

Figure A-24 Low-Severity L&T Cracking



Figure A-25 Medium-Severity L&T Cracking



Figure A-26 High-Severity L&T Cracking



A-9.4 Longitudinal and Transverse Cracking (Non-PCC Joint Reflective) in Porous Friction Courses (PFC): Severity Levels.

Note: These severity levels are in addition to the existing definitions.

L Cracks have either minor spalling (little or no FOD potential) or no spalling. The cracks can be filled or non-filled. Non-filled cracks have a mean width of 0.25 inch (6 millimeters) or less; filled cracks are of any width but their filler material is in satisfactory condition. Furthermore, the average raveled area (area with dislodged or missing coarse aggregate larger than 0.19 inch [4.75 millimeters]) around the crack is less than 0.25 inch (6 millimeters) wide.

M The average raveled area (area with dislodged or missing coarse aggregate larger than 0.19 inch [4.75 millimeters]) around the crack is 0.25 to 1 inch (6 to 25 millimeters) wide or one of these conditions exists: (1) cracks are moderately spalled (some FOD potential) and can be either filled or non-filled of any width; (2) filled cracks are not spalled or are only lightly spalled, but the filler is in unsatisfactory condition; (3) non-filled cracks are not spalled or are only lightly spalled but the mean crack width is greater than 0.25 inch (6 millimeters); or (4) light random cracking exists near the crack or at the corners of intersecting cracks.

H The average raveled area (area with dislodged or missing coarse aggregate larger than 0.19 inch [4.75 millimeters]) around the crack is greater than 1 inch (25 millimeters) wide or cracks are severely spalled, causing definite FOD potential. They can be either filled or non-filled of any width.

A-9.5 How to Measure.

L&T cracks are measured in linear feet (linear meters). Identify and record the length and severity of each crack. If the crack does not have the same severity level along its entire length, separately record each portion of the crack with a different severity level. For an example, see the explanation of how to measure joint reflection cracking in paragraph A-8.3. If block cracking is recorded, L&T cracking are not recorded in the same area.

Figure A-27 Low-Severity PFC L&T Cracking

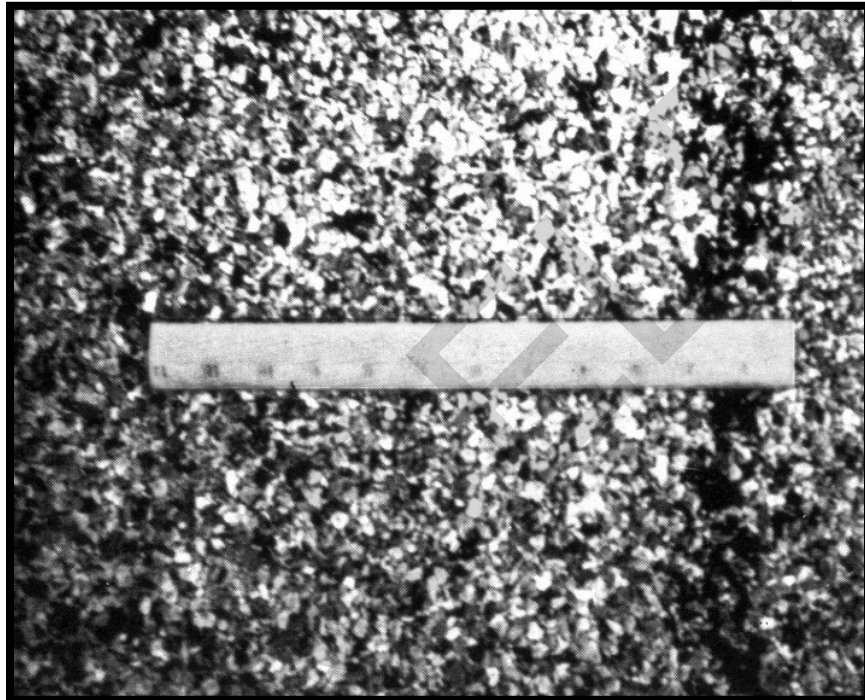

Figure A-28 Medium-Severity PFC L&T Cracking

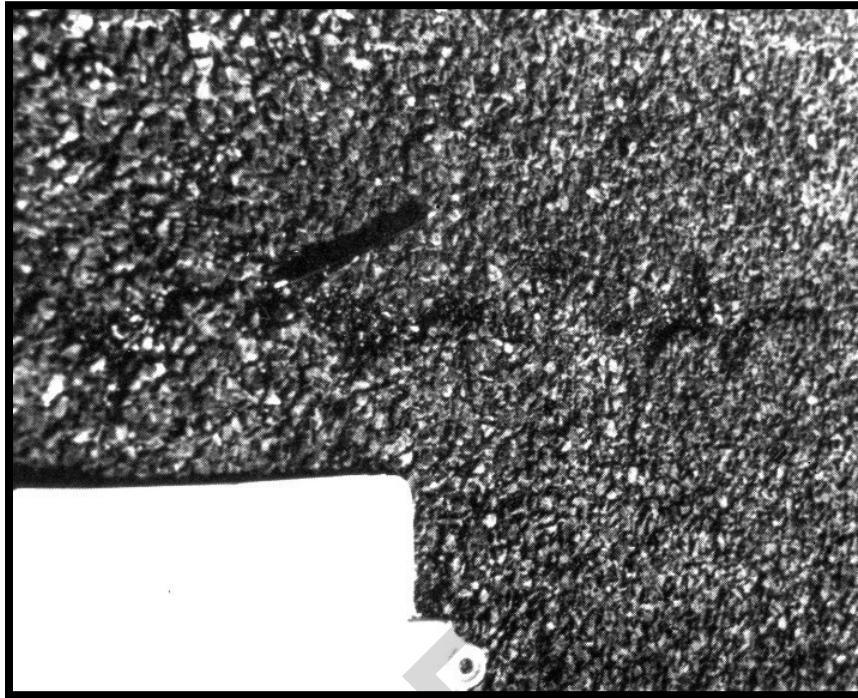

Figure A-29 Medium-Severity PFC L&T Cracking



Figure A-30 High-Severity PFC L&T Cracking



A-10 OIL SPILLAGE (49) {9}.

A-10.1 Description.

Oil spillage is the deterioration or softening of the pavement surface caused by the spilling of oil, fuel, or other solvents.

A-10.2 Severity Levels.

No degrees of severity are defined. It is sufficient to indicate that oil spillage exists.

A-10.3 How to Measure.

Oil spillage is measured in square feet (square meters) of surface area. A stain is not a distress unless material has been lost or the binder has been softened. If hardness is approximately the same as on surrounding pavement and if no material has been lost, do not record as a distress.

Figure A-31 Oil Spill



A-11 PATCHING AND UTILITY CUT PATCH (50) {10}.

A-11.1 Description.

A patch is considered a defect, regardless of how well it is performing.

A-11.2 Severity Levels.

L Patch is in good condition and performing satisfactorily; little or no FOD potential.

M Patch is somewhat deteriorated and affects riding quality to some extent; some FOD potential.

H Patch is badly deteriorated and affects riding quality significantly or has high FOD potential. Patch needs replacement.

The use of dense-graded AC patches on PCC surfaces causes a water-damming effect at the patch that contributes to differential skid resistance of the surface. Rate low-severity, dense-graded patches as medium-severity patches because of the differential friction problem. Medium- and high-severity patches are rated the same as above.

A-11.3 How to Measure.

Patching is measured in square feet (square meters) of surface area; however, if a single patch has areas of differing severity levels, measure and record these areas separately. For example, a 25-square-foot (2.5-square-meter) patch may have 10 square feet (1 square meter) of medium severity and 15 square feet (1.5 square meters) of low severity. Record these areas separately. Any distress found in a patched area is

not recorded; however, its effects on the patch will be considered when determining the patch's severity level.

A very large patch (area > 2,500 square feet [230 square meters]) or feathered-edge pavement may qualify as an additional sample unit or a separate section.

Figure A-32 Low-Severity Patching



Figure A-33 Medium-Severity Patching



CANCELLED

Figure A-34 High-Severity Patching



A-12 POLISHED AGGREGATE (51) {11}.

A-12.1 Description.

Aggregate polishing is caused by repeated traffic applications. Polished aggregate is present when close examination of a pavement reveals that the portion of aggregate extending above the asphalt is either very small or there are no rough or angular aggregate particles to provide good skid resistance. Existence of this type of distress is also indicated when the number on a skid resistance rating test is low or has dropped significantly from previous ratings.

A-12.2 Severity Levels.

No degrees of severity are defined; however, when the degree of polishing is significant, polishing is included in the condition survey and rated as a defect.

A-12.3 How to Measure.

Polished aggregate is measured in square feet (square meters) of surface area. If bleeding is counted, polished aggregate is not counted in the same area.

Figure A-35 Polished Aggregate



A-13 RAVELING (52) {12}.

A-13.1 Description.

Raveling is the dislodging or loss of coarse aggregate particles (stone or rocks larger than 0.19 inch [4.75 millimeters]) from the pavement surface. This is characterized by aggregates larger than 0.19 inch (4.75 millimeters) missing or no longer bound to the surface.

A-13.2 Dense Mix Severity Levels.

As used herein, “coarse aggregate” refers to predominant coarse aggregate sizes of the asphalt mix. The term “aggregate clusters” refers to when more than one adjoining coarse aggregate piece is missing. If in doubt about a severity level, examine three representative areas of 1 square yard (1 square meter) each and count the number of missing coarse aggregate particles.

L One of these conditions exists: (1) in a 1-square-yard (1-square-meter) representative area, the number of coarse aggregate particles missing is between five and twenty; or (2) missing aggregate clusters are less than 2 percent of the examined 1-square-yard (1-square-meter) area. In low-severity raveling, there is little or no FOD potential.

M One of these conditions exists: (1) in a 1-square-yard (1-square-meter) representative area, the number of coarse aggregate particles missing is between 21 and 40; or (2) missing aggregate clusters are between 2 and 10 percent of the examined 1-square-yard (1-square-meter) area. In medium-severity raveling, there is some FOD potential.

H One of these conditions exists: (1) in a 1-square-yard (1-square-meter) representative area, the number of coarse aggregate particles missing is over 40; or (2) missing aggregate clusters are more than 10 percent of the examined 1-square-yard (1-square-meter) area. In high-severity raveling, there is significant FOD potential.

A-13.3 How to Measure.

Raveling is measured in square feet (square meters) of surface area. Mechanical damage caused by hook drags, tire rims, or snowplows is counted as areas of high-severity raveling.

Figure A-36 Low-Severity Raveling (Dense Mix)



Figure A-37 Medium-Severity Raveling (Dense Mix)



Figure A-38 High-Severity Raveling (Dense Mix)



A-13.4 Slurry Seal/Coal Tar Over Dense Mix Severity Levels.

L (1) The scaled area is less than 1 percent. (2) In the case of coal tar where pattern cracking has developed, the surface cracks are less than 0.25 inch (6 millimeters) wide.

M (1) The scaled area is between 1 and 10 percent. (2) In the case of coal tar where pattern cracking has developed, the cracks are 0.25 inch (6 millimeters) wide or greater.

H (1) The scaled area is over 10 percent. (2) In the case of coal tar, the surface is peeling off.

A-13.5 How to Measure.

Raveling is measured in square feet (square meters) of surface area. Mechanical damage caused by hook drags, tire rims, or snowplows is counted as areas of high-severity raveling.

Figure A-39 Low-Severity Raveling (Slurry Seal/Coal Tar Over Dense Mix)



Figure A-40 Medium-Severity Raveling (Slurry Seal/Coal Tar Over Dense Mix)



Figure A-41 High-Severity Raveling (Slurry Seal/Coal Tar Over Dense Mix)



A-13.6 Porous Friction Course (PFC) Severity Levels.

L In a 1-square-foot (0.1-square-meter) representative sample, the number of aggregate pieces missing is between five and twenty and/or the number of missing aggregate clusters does not exceed one.

M In a 1-square-foot (0.1-square-meter) representative sample, the number of aggregate pieces missing is between 21 and 40 and/or the number of missing aggregate clusters is greater than one but does not exceed 25 percent of the area.

H In a 1-square-foot (0.1-square-meter) representative sample, the number of aggregate pieces missing is over 40 and/or the number of missing aggregate clusters is greater than 25 percent of the area.

A-13.7 How to Measure.

Raveling is measured in square feet (square meters) of surface area. Mechanical damage caused by hook drags, tire rims, or snowplows is counted as areas of high-severity raveling.

Figure A-42 Low-Severity Raveling (PFC)



Figure A-43 Medium-Severity Raveling (PFC)



Figure A-44 Medium-Severity Raveling (PFC)



Figure A-45 High-Severity Raveling (PFC)



A-14 RUTTING (53) {13}.

A-14.1 Description.

A rut is a surface depression in the wheel path. Pavement uplift may occur along the sides of the rut; however, in many instances, ruts are noticeable only after a rainfall, when the wheel paths are filled with water. Rutting stems from a permanent deformation in any of the pavement layers or subgrade. It is usually caused by consolidation or lateral movement of the materials due to traffic loads. Significant rutting can lead to major structural failure of the pavement.

A-14.2 How to Measure.

Rutting is measured in square feet (square meters) of surface area and the severity is determined by the mean depth of the rut. The mean rut depth is calculated in inches (millimeters) by laying a straightedge across the rut, measuring the depth, then using measurements taken along the length of the rut to compute the mean.

Table A-4. Mean Rut Depth Criteria

Severity	All Pavement Sections
L	0.25 to 0.5 inch (6 to 13 mm)
M	0.5 to 1 inch (13 to 25 mm)
H	> 1 inch (> 25 mm)

Figure A-46 Rutting



A-15 SHOVING OF ASPHALT PAVEMENT BY PCC SLABS (54) {14}.

A-15.1 Description.

PCC pavements occasionally increase in length at ends where they adjoin flexible pavements (commonly referred to as “pavement growth”). This “growth” shoves the asphalt- or tar-surfaced pavements, causing them to swell and crack. The PCC slab growth is caused by a gradual opening of the joints as they are filled with incompressible materials that prevent them from reclosing.

A-15.2 Severity Levels.

As a guide, Table A-5 is used to determine the severity levels of shoving. At present, no significant research has been conducted to quantify levels of severity of shoving.

Table A-5. Shoving Criteria

Severity	Height Differential
L	< 0.75 inch (< 19 mm)
M	0.75 to 1.5 inch (19 mm to 38 mm)
H	> 1.5 inch (> 38 mm)

L A slight amount of shoving has occurred, with little effect on ride quality and no breakup of the asphalt pavement.

M A significant amount of shoving has occurred, causing moderate roughness or breakup of the asphalt pavement.

H A large amount of shoving has occurred, causing severe roughness or breakup of the asphalt pavement.

A-15.3 How to Measure.

Shoving is measured by determining the area in square feet (square meters) of the swell caused by shoving.

Figure A-47 Low-Severity Shoving

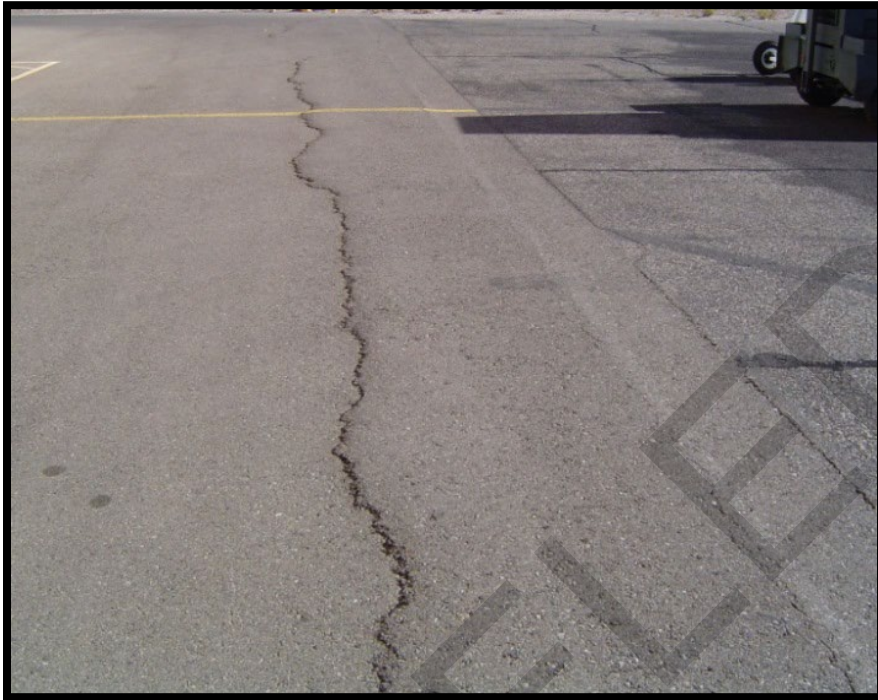

Figure A-48 Medium-Severity Shoving



Figure A-49 High-Severity Shoving



A-16 SLIPPAGE CRACKING (55) {15}.

A-16.1 Description.

Slippage cracks are crescent- or half-moon-shaped cracks having two ends pointed in the direction of traffic. They are produced when braking or turning wheels cause the pavement surface to slide and deform. This usually occurs when there is a low-strength surface mix or poor bond between the surface and next layer of pavement structure.

A-16.2 Severity Levels.

No degrees of severity are defined. It is sufficient to indicate that a slippage crack exists.

A-16.3 How to Measure.

Slippage cracking is measured in square feet (square meters) of surface area.

Figure A-50 Slippage Cracking



A-17 SWELL (56) {16}.

A-17.1 Description.

A swell is characterized by an upward bulge in the pavement's surface. A swell may occur sharply over a small area or as a longer, gradual wave. Either type of swell can be accompanied by surface cracking. A swell is usually caused by frost action in the subgrade or by swelling soil but a small swell can also occur on the surface of an asphalt overlay (over PCC) as a result of a blowup in the PCC slab.

A-17.2 Severity Levels.

L Swell is barely visible and has a minor effect on the pavement's ride quality as determined at the normal aircraft speed for the pavement section under consideration. (Low-severity swells are not always observable but their existence can be confirmed by driving a vehicle over the section at the normal aircraft speed. An upward acceleration will occur if the swell is present.)

M Swell can be observed without difficulty and has a significant effect on the pavement's ride quality as determined at the normal aircraft speed for the pavement section under consideration.

H Swell can be readily observed and severely affects the pavement's ride quality at the normal aircraft speed for the pavement section under consideration.

A-17.3 How to Measure.

The surface area of the swell is measured in square feet (square meters). Consider the type of pavement section (i.e., runway, taxiway, or apron) when determining the severity

rating. For example, a swell of sufficient magnitude to cause considerable roughness on a runway at high speeds would be rated as more severe than the same swell located on the apron or taxiway where the normal aircraft operating speeds are much lower. The guidance in Table A-6 is provided for runways:

Table A-6. Swell Criteria

Severity	Height Differential
L	< 0.75 inch (< 19 mm)
M	0.75 to 1.5 inch (19 to 38 mm)
H	> 1.5 inch (> 38 mm)

Figure A-51 Low-Severity Swell



Figure A-52 Medium-Severity Swell



Figure A-53 High-Severity Swell



A-18 WEATHERING (SURFACE WEAR) – DENSE MIX ASPHALT (57) {17}.

A-18.1 Description.

Weathering is the wearing away of the asphalt binder and fine aggregate matrix from the pavement surface.

A-18.2 Severity Levels.

L Asphalt surface is beginning to show signs of aging that may be accelerated by climatic conditions. Loss of the fine aggregate matrix is noticeable and may be accompanied by fading of the asphalt color. Edges of the coarse aggregates are beginning to be exposed (less than 0.04 inch [1 millimeter]). Pavement may be relatively new (as new as six months old).

M Loss of fine aggregate matrix is noticeable and edges of coarse aggregate have been exposed up to one-fourth of the width (of the longest side) of the coarse aggregate due to the loss of fine aggregate matrix.

H Edges of coarse aggregate have been exposed greater than one-fourth of the width (of the longest side) of the coarse aggregate. There is considerable loss of fine aggregate matrix, leading to potential or some loss of coarse aggregate.

A-18.3 How to Measure.

Weathering (surface wear) is measured in square feet (square meters). Weathering (surface wear) is not recorded if medium- or high-severity raveling is recorded.

Figure A-54 Low-Severity Weathering



Figure A-55 Medium-Severity Weathering



Figure A-56 High-Severity Weathering



APPENDIX B DISTRESS DEFINITIONS -CONCRETE-SURFACED AIRFIELDS

B-1 INTRODUCTION.

This appendix contains distress definitions and measuring methods for concrete-surfaced airfields. This information is used to determine the pavement condition index (PCI).

Note: Each distress definition is followed by a number in parentheses, indicating the PAVER distress code, and a number in braces, indicating the ASTM D5340 distress code, i.e.,

“Distress (#) {#}.” See Table 3-6.

Table B-1 Frequently Occurring Problems in Pavement Distress Identification

Situation	Action	Remarks
Low-severity scaling (i.e., crazing)	Count only if possible future scaling will occur within 2 to 3 years	
Joint seal damage	This is not counted on a slab-by-slab basis	A severity level based on the overall condition of the joint seal in the sample unit is assigned
Joint spall small enough to be filled during a joint seal repair	Do not record	
Medium- or high-severity intersecting crack (shattered slab)	Do not count any other distress	
Corner or joint spalling caused by “D” cracking	Record only “D” cracking	If spalls are caused by factors other than “D” cracking, record each factor separately
Crack repaired by a narrow patch (e.g., 4 to 10 in. [100 to 250 mm] wide)	Record only crack and not patch at appropriate severity level	
Original distress of patch more severe than patch itself	Record original distress type	If, for example, patch material is present on scaled area of slab, only the scaling is counted

Situation	Action	Remarks
Hairline cracks that are only a few feet (meters) long and do not extend across the entire slab	Rate as shrinkage cracks.	

B-2 BLOWUP (61) {1}.

B-2.1 Description.

Blowups occur in hot weather, usually at a transverse crack or joint that is not wide enough to permit expansion by the concrete slabs. The insufficient width is usually caused by infiltration of incompressible materials into the joint space. When expansion cannot relieve enough pressure, a localized upward movement of the slab edges (buckling) or shattering will occur in the vicinity of the joint. Blowups can also occur at utility cuts and drainage inlets. This type of distress is almost always repaired immediately because of the severe damage potential to aircraft. Blowups are included for reference when closed sections are being evaluated for reopening.

B-2.2 Severity Levels.

L Buckling or shattering has not rendered the pavement inoperative and only a slight amount of roughness exists.

M Buckling or shattering has not rendered the pavement inoperative but a significant amount of roughness exists.

H Buckling or shattering has rendered the pavement inoperative.

Note: For pavements to be considered operational, all foreign material from blowups must have been removed.

B-2.3 How to Count.

A blowup usually occurs at a transverse crack or joint. At a crack, a blowup is counted as being in one slab, but at a joint, two slabs are affected and the distress is recorded as occurring in two slabs.

Figure B-1 Low-Severity Blowup



Figure B-2 Low-Severity Blowup



Figure B-3 Medium-Severity Blowup



Figure B-4 High-Severity Blowup



B-3 CORNER BREAK (62) {2}.

B-3.1 Description.

A corner break is a crack that intersects the joints at a distance less than or equal to one-half the slab length on both sides, measured from the corner of the slab. For example, a slab that is 25 by 25 feet (7.5 by 7.5 meters) and has a crack intersecting the joint 5 feet (1.5 meters) from the corner on one side and 17 feet (5 meters) on the other side is not considered a corner break—it is a diagonal crack. However, a crack that intersects 7 feet (2 meters) on one side and 10 feet (3 meters) on the other is considered a corner break. A corner break differs from a corner spall in that the crack extends vertically through the entire slab thickness while a corner spall intersects the joint at an angle. Load repetition combined with loss of support and curling stresses causes corner breaks.

B-3.2 Severity Levels.

L Crack has either no spalling or minor spalling (no FOD potential). If non-filled, it has a mean width less than approximately 0.125 inch (3 millimeters); a filled crack can be of any width, but the filler material must be in satisfactory condition. The area between the corner break and the joints is not cracked.

M One of these conditions exists: (1) a filled or non-filled crack is moderately spalled (some FOD potential); (2) a non-filled crack has a mean width between 0.125 inch (3 millimeters) and 1 inch (25 millimeters); (3) a filled crack is not spalled or only lightly spalled but the filler is in unsatisfactory condition; or (4) the area between the corner break and the joints is lightly cracked. “Lightly cracked” means one low-severity crack dividing the corner into two pieces.

H One of these conditions exists: (1) a filled or non-filled crack is severely spalled, causing definite FOD potential; (2) a non-filled crack has a mean width greater than approximately 1 inch (25 millimeters), creating tire damage potential; or (3) the area between the corner break and the joints is severely cracked.

B-3.3 How to Count.

A distressed slab is recorded as one slab if it (1) contains a single corner break, (2) contains more than one break of a particular severity, or (3) contains two or more breaks of different severities. For two or more breaks, record the highest level of severity. For example, count as one slab with a medium-severity corner break a slab containing both low- and medium-severity corner breaks. Measure crack widths between vertical walls, not in spalled areas of the crack. If the corner break is faulted 0.125 inch (3 millimeters) or more, increase severity to the next higher level. If the corner is faulted more than 0.5 inch (13 millimeters), rate the corner break at high severity. If faulting in the corner is incidental to faulting in the slab, rate faulting separately. The angle of crack into the slab is usually not evident at low severity. Unless the crack angle can be determined, to differentiate between a corner break and corner spall, use these criteria: If the crack intersects both joints more than 2 feet (600

millimeters) from the corner, it is a corner break. If less than 2 feet (600 millimeters), unless you can verify the crack is vertical, it is a spall.

Figure B-5 Low-Severity Corner Break



Figure B-6 Medium-Severity Corner Break



Figure B-7 High-Severity Corner Break



B-4 LINEAR CRACKS (LONGITUDINAL, TRANSVERSE, AND DIAGONAL) (63) {3}.

B-4.1 Description.

These cracks, which divide the slab into two or three pieces, are usually caused by a combination of load repetition, curling stresses, and shrinkage stresses. (For slabs divided into four or more pieces, see shattered slab/intersecting cracks, paragraph B-13.) Low-severity cracks are usually warping- or friction-related and are not considered major structural distresses. Medium- or high-severity cracks are usually working cracks and are considered major structural distresses.

Hairline cracks that are only a few feet (meters) long and do not extend across the entire slab are rated as shrinkage cracks.

B-4.2 Non-reinforced PCC Severity Levels.

L Crack has no spalling or minor spalling (no FOD potential). If non-filled, it is less than 0.125 inch (3 millimeters) wide. A filled crack can be of any width but its filler material must be in satisfactory condition or the slab is divided into three pieces by low-severity cracks.

M One of these conditions exists: (1) a filled or non-filled crack is moderately spalled (some FOD potential); (2) a non-filled crack has a mean width between 0.125 inch (3 millimeters) and 1 inch (25 millimeters); (3) a filled crack has no spalling or minor spalling but the filler is in unsatisfactory condition; or (4) the slab is divided into three pieces by two or more cracks, one of which is at least medium severity.

H One of the following conditions exists: (1) a filled or non-filled crack is severely spalled (definite FOD potential); (2) a non-filled crack has a mean width approximately greater than 1 inch (25 millimeters), creating tire damage potential; or (3) the slab is divided into three pieces by two or more cracks, one of which is at least high severity.

B-4.3 How to Count.

Once the severity has been identified, the distress is recorded as one slab. If a crack is repaired by a narrow patch (e.g., 4 to 10 inches wide [100 to 250 millimeters]), record only the crack and not the patch at the appropriate severity level.

Cracks used to define and rate corner breaks, “D” cracks, patches, shrinkage cracks, and spalls are not recorded as longitudinal/transverse/diagonal cracks.

Figure B-8 Low-Severity Linear Cracks



Figure B-9 Medium-Severity Linear Cracks



Figure B-10 High-Severity Linear Cracks

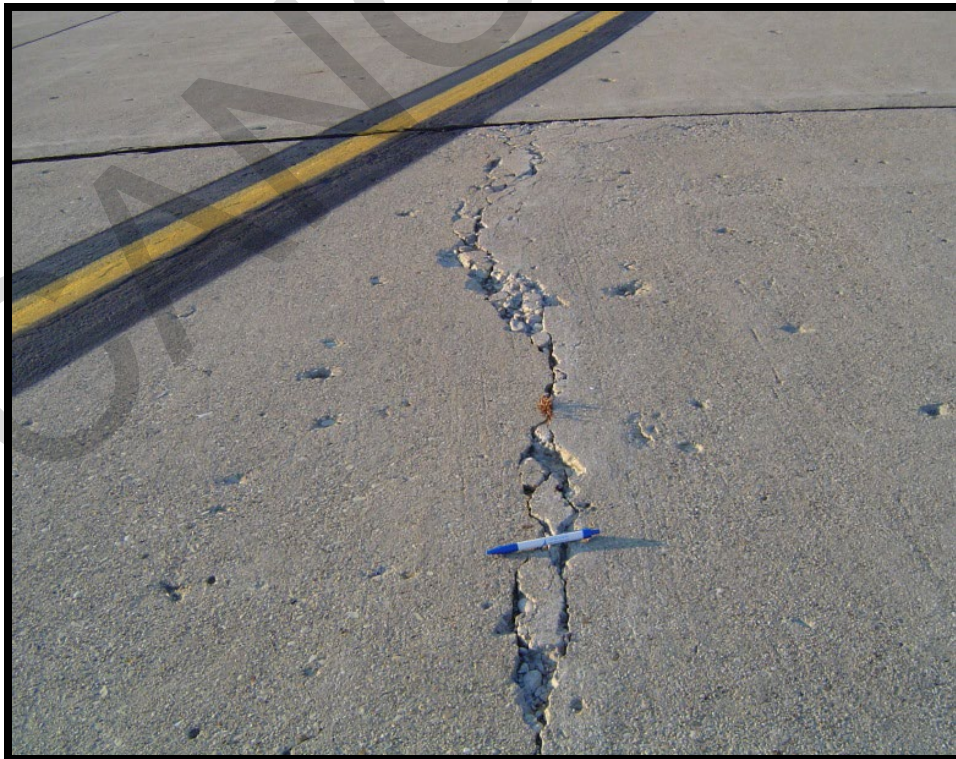

B-4.4 Reinforced Concrete Severity Levels.

L (1) Non-filled crack, 0.125 inch (3 millimeters) to 0.5 inch (13 millimeters) wide, with no faulting or spalling; (2) filled or non-filled cracks of any width < 0.5 inch (13 millimeters), with low-severity spalling; or (3) filled cracks of any width (filler satisfactory) with no faulting or spalling. **Note:** A crack less than 0.125 inch (3 millimeters) wide with no spalling or faulting is counted as shrinkage cracking.

M (1) Non-filled cracks, 0.5 inch (13 millimeters) to 1 inch (25 millimeters) wide, with no faulting or spalling; (2) filled cracks of any width with faulting < 0.375 inch (10 millimeters) or medium-severity spalling; or (3) non-filled cracks of width < 1 inch (25 millimeters) with faulting < 0.375 inch (10 millimeters) or medium-severity spalling.

H (1) Non-filled cracks of width > 1 inch (25 millimeters); (2) non-filled cracks of any width with faulting > 0.375 inch (10 millimeters) or medium-severity spalling; or (3) filled cracks of any width with faulting > 0.375 inch (10 millimeters) or high-severity spalling.

B-4.5 How to Count.

Once the severity has been identified, the distress is recorded as one slab. If a crack is repaired by a narrow patch (e.g., 4 to 10 inches wide [100 to 250 millimeters]), only the crack and not the patch are recorded at the appropriate severity level. Slabs longer than 30 feet (9 meters) are divided into approximately equal length "slabs" having imaginary joints assumed to be in perfect condition.

Figure B-11 Cracks (Reinforced PCC)

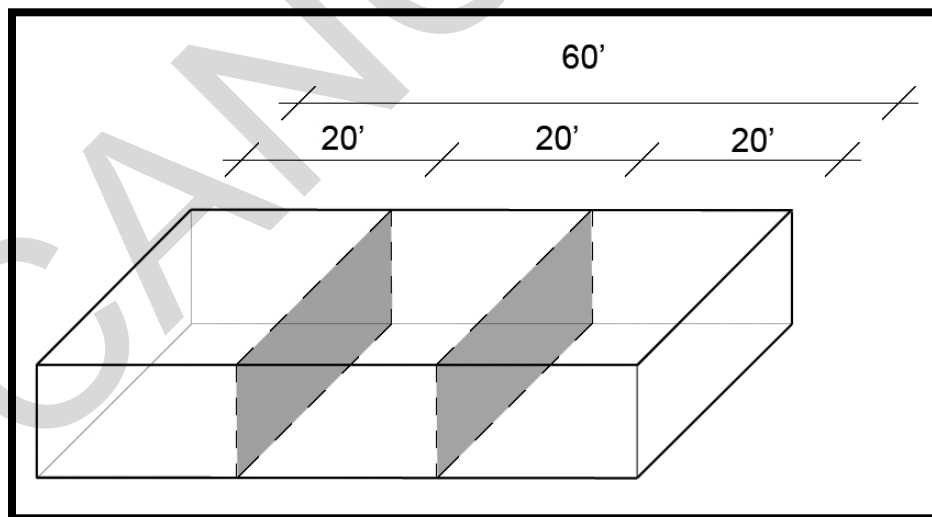

B-5 DURABILITY ("D") CRACKING (64) {4}.

B-5.1 Description.

Durability cracking is caused by the inability of the concrete to withstand environmental factors such as freeze-thaw cycles. It usually appears as a pattern of cracks running parallel to a joint or linear crack. A dark coloring is usually seen around the fine

durability cracks. This type of cracking may eventually lead to disintegration of the concrete within 1 to 2 feet (0.3 to 0.6 meter) of the joint or crack.

B-5.2 Severity Levels.

L “D” cracking is defined by hairline cracks occurring in a limited area of the slab, such as one or two corners along one joint. Little or no disintegration has occurred. No FOD potential.

M (1) “D” cracking has developed over a considerable amount of slab area with little or no disintegration or FOD potential; or (2) “D” cracking has occurred in a limited area of the slab, such as in one or two corners or along one joint but pieces are missing and disintegration has occurred. Some FOD potential.

H “D” cracking has developed over a considerable amount of slab area with disintegration or FOD potential.

B-5.3 How to Count.

When the distress is located and rated at one severity, it is counted as one slab. If more than one severity level is found, the slab is counted as having the higher severity distress. If “D” cracking is counted, do not record scaling on the same slab.

Figure B-12 Low-Severity “D” Cracking



Figure B-13 Medium-Severity “D” Cracking



Figure B-14 High-Severity “D” Cracking



B-6 JOINT SEAL DAMAGE (65) {5}.

B-6.1 Description.

Joint seal damage is any condition that enables soil or rocks to accumulate in the joints or allows significant infiltration of water. Accumulation of incompressible materials prevents the slabs from expanding and may result in buckling, shattering, or spalling. Pliable joint filler bonded to the edges of the slabs protects the joints from accumulating materials and prevents water from seeping down and softening the foundation supporting the slab. Typical types of joint seal damage are (a) stripping of joint sealant, (b) extrusion of joint sealant, (c) weed growth, (d) hardening of the filler (oxidation), (e) loss of bond to the slab edges, and (f) lack or absence of sealant in the joint.

B-6.2 Severity Levels.

L Joint sealer is in generally good condition throughout the sample. Sealant is performing well, with only a minor amount of any of the above types of damage present. Joint seal damage is at low severity if a few of the joints have sealer that has debonded from, but is still in contact with, the joint edge. This condition exists if a knife blade can be inserted between the sealer and joint face without resistance.

M Joint sealer is in generally fair condition over the entire surveyed section, with one or more of the above types of damage occurring to a moderate degree. Sealant needs replacement within two years. Joint seal damage is at medium severity if a few of the joints have any of these conditions: (1) joint sealer is in place but water access is possible through visible openings no more than 0.125 inch (3 millimeters) wide. If a knife blade cannot be inserted easily between sealer and joint face, this condition does not exist; (2) pumping debris is evident at the joint; (3) joint sealer is oxidized and "lifeless" but pliable (like a rope) and generally fills the joint opening; or (4) vegetation in the joint is obvious but does not obscure the joint opening.

H Joint sealer is in generally poor condition over the entire surveyed section, with one or more of the above types of damage occurring to a severe degree. Sealant needs immediate replacement. Joint seal damage is at high severity if 10 percent or more of the joint sealer exceeds the limiting criteria listed above or if 10 percent or more of the sealer is missing.

B-6.3 How to Count.

Joint seal damage is not counted on a slab-by-slab basis but is rated based on the overall condition of the sealant in the sample unit. Joint sealer is in satisfactory condition if it prevents entry of water into the joint, has some elasticity, and if no vegetation is growing between the sealer and joint face. Premolded sealer is rated using the same criteria as above except as follows: (1) premolded sealer is elastic and is firmly pressed against the joint walls and (2) premolded sealer is below the joint edge. If the sealer extends above the surface, it can be caught by moving equipment such as snow plows or brooms and pulled out of the joint. Premolded sealer is recorded at low severity if any part is visible above the joint edge. It is at medium severity if 10 percent or more of the

length is above the joint edge or if any part is more than 0.5 inch (13 millimeters) above the joint edge. It is at high severity if 20 percent or more is above the joint edge, if any part is more than 1 inch (25 millimeters) above the joint edge, or if 10 percent or more is missing. Rate joint sealer by joint segment. Sample unit rating is the same as the most severe rating held by at least 20 percent of the segments rated. In rating oxidation, do not rate on appearance, rate on resilience. Some joint sealer will have a very dull surface and may even show surface cracks in the oxidized layer. If the sealer is performing satisfactorily and has good characteristics beneath the surface, it is satisfactory.

Figure B-15 Low-Severity Joint Seal Damage



Figure B-16 Medium-Severity Joint Seal Damage



Figure B-17 High-Severity Joint Seal Damage



B-7 PATCHING, SMALL (LESS THAN 5.5 FT² [0.5 M²]) (66) {6}.

B-7.1 Description.

A patch is an area where the original pavement has been removed and replaced by a filler material. For condition evaluation, patching is divided into two types: small (less than 5.5 square feet [0.5 square meter]) and large (over 5.5 square feet [0.5 square meter]). Large patches are described in the next section.

B-7.2 Severity Levels.

L Patch is functioning well, with little or no deterioration.

M Patch has deteriorated and/or moderate spalling can be seen around the edges. Patch material can be dislodged with considerable effort (minor FOD potential).

H Patch has deteriorated, either by spalling around the patch or cracking within the patch, to a state that warrants replacement.

B-7.3 How to Measure.

If one or more small patches having the same severity level are located in a slab, it is counted as one slab containing that distress. If more than one severity level occurs, it is counted as one slab, with the higher severity level being recorded. If a crack is repaired by a narrow patch (e.g., 4 to 10 inches [100 to 250 millimeters] wide), only the crack and not the patch is recorded at the appropriate severity level. If the original distress of a patch is more severe than the patch itself, the original distress type is recorded.

Figure B-18 Low-Severity Small Patch



Figure B-19 Medium-Severity Small Patch



Figure B-20 High-Severity Small Patch



B-8 PATCHING, LARGE (OVER 5.5 FT² [0.5 M²]) AND UTILITY CUT (67) {7}.

B-8.1 Description.

Patching is the same as defined in paragraph B-7. A utility cut is a patch that has replaced the original pavement because of placement of underground utilities. The severity levels of a utility cut are the same as those for regular patching.

B-8.2 Severity Levels.

L Patch is functioning well, with very little or no deterioration.

M Patch has deteriorated and/or moderate spalling is visible around the edges. Patch material can be dislodged with considerable effort, causing some FOD potential.

H Patch has deteriorated to a state that causes considerable roughness and/or high FOD potential. The extent of the deterioration warrants replacement of the patch.

B-8.3 How to Count.

The criteria are the same as for small patches (paragraph B-7).

Figure B-21 Low-Severity Large Patch



Figure B-22 Medium-Severity Large Patch



Figure B-23 High Severity Large Patch



B-9 POPOUTS (68) {8}.

B-9.1 Description.

A popout is a small piece of pavement that breaks loose from the surface due to freeze-thaw action in combination with expansive aggregates. Popouts usually range from approximately 1 inch (25 millimeters) to 4 inches (100 millimeters) in diameter and from 0.5 inch (13 millimeters) to 2 inches (50 millimeters) deep.

B-9.2 Severity Levels.

No degrees of severity are defined for popouts; however, when popouts are extensive, they are counted as a distress; i.e., average popout density exceeds approximately three popouts per square yard (square meter) over the entire slab area.

B-9.3 How to Count.

Always measure the density of the distress. If there is any doubt about the average being greater than three popouts per square yard (square meter), at least three random 1-square-yard (1-square-meter) areas are checked. When the average is greater than this density, the slab is counted.

Figure B-24 Popouts



B-10 PUMPING (69) {9}.

B-10.1 Description.

Pumping is the ejection of material by water through joints or cracks caused by deflection of the slab under passing loads. As the water is ejected, it carries particles of gravel, sand, clay, or silt and results in a progressive loss of pavement support. Surface staining and base or subgrade material on the pavement close to joints or cracks are evidence of pumping. Pumping near joints indicates poor joint sealer and loss of support, which will lead to cracking under repeated loads. Identify the joint seal as defective before pumping can be said to exist. Pumping can occur at cracks as well as joints.

B-10.2 Severity Levels.

No degrees of severity are defined. It is sufficient to indicate that pumping exists.

B-10.3 How to Count.

Slabs are counted as follows: one pumping joint between two slabs is counted as two slabs; however, if the remaining joints around the slab are also pumping, one slab is added per additional pumping joint.

Figure B-25 Pumping



Figure B-26 Pumping



B-11 SCALING (70) {10}.

B-11.1 Description.

B-11.1.1 Scaling is surface deterioration caused by construction defects, material defects, and environmental factors. Generally, scaling is exhibited by delamination or disintegration of the slab surface to the depth of the defect.

B-11.1.2 Construction defects include over-finishing, addition of water to the pavement surface during finishing, lack of curing, and attempted surface repairs of fresh concrete with mortar. Generally, this occurs over a portion of a slab.

B-11.1.3 Material defects include inadequate air entrainment for the climate. Generally, this occurs over several slabs that were affected by the concrete batches.

B-11.1.4 Environmental factors include freezing of concrete before adequate strength is gained and thermal cycles from certain aircraft. Generally, this occurs over a large area for freezing and in isolated areas for thermal effects.

B-11.1.5 Typically, the FOD from scaling is removed by sweeping but the concrete will continue to scale until the affected depth is removed or expended.

B-11.2 Severity Levels.

L Minimal loss of surface paste that poses no FOD hazard. No FOD potential.

M The loss of surface paste that poses some FOD potential, including isolated fragments of loose mortar, exposure of the sides of coarse aggregate (less than one-fourth of the width of the coarse aggregate), or evidence of coarse aggregate coming loose from the surface.

H The high severity is associated with low-durability concrete that will continue to pose a high FOD hazard. Typically, the layer of surface mortar is observable at the perimeter of the scaled area and is likely to continue to scale due to environmental or other factors. Indication of high-severity FOD is that routine sweeping is not sufficient to avoid FOD issues.

B-11.3 How to Count.

If two or more levels of severity exist on a slab, the slab is counted as one slab having the maximum level of severity. If "D" cracking or alkali-silica reaction (ASR) is counted, scaling is not counted.

Figure B-27 Low-Severity Scaling



Figure B-28 Medium-Severity Scaling



Figure B-29 High-Severity Scaling



B-12 SETTLEMENT OR FAULTING (71) {11}.

B-12.1 Description.

Settlement or faulting is a difference of elevation at a joint or crack caused by upheaval or consolidation.

B-12.2 Severity Levels.

Severity levels are defined by the difference in elevation across the fault and the associated decrease in ride quality and safety as severity increases.

Table B-2. Difference in Elevation

Severity	Runways/ Taxiways	Aprons
L	< 0.25 inch (< 6 mm)	0.125–0.5 inch (3–13 mm)
M	0.25–0.5 inch (6–13 mm)	0.5–1 inch (13–25 mm)
H	> 0.5 inch (> 13 mm)	> 1 inch (> 25 mm)

B-12.3 How to Count.

In counting settlement, a fault between two slabs is counted as one slab. A straightedge or level is used to aid in measuring the difference in elevation between the two slabs.

Construction-induced elevation differential is not rated in PCI procedures. Where construction differential exists, it can often be identified by the way the high side of the joint was rolled down by finishers (usually within 6 inches [150 millimeters] of the joint) to meet the low-slab elevation.

Figure B-30 Low-Severity Settlement or Faulting



Figure B-31 Low-Severity Settlement or Faulting



Figure B-32 High-Severity Settlement or Faulting

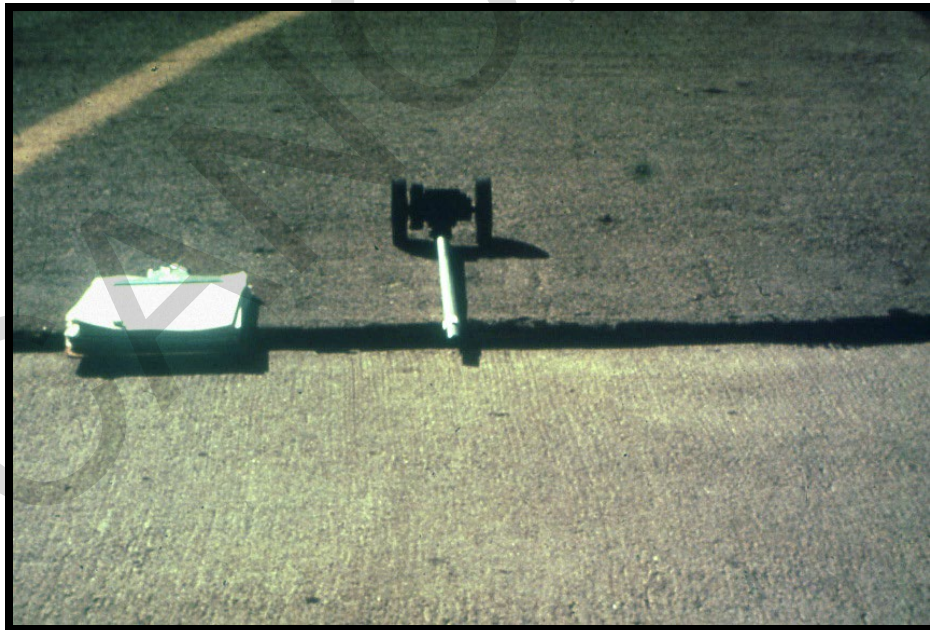

B-13 SHATTERED SLAB/INTERSECTING CRACKS (72) {12}.

B-13.1 Description.

Intersecting cracks are cracks that break the slab into four or more pieces because of overloading and/or inadequate support. The high-severity level of this distress type, as

defined below, is referred to as a shattered slab. If all pieces or cracks are contained within a corner break, the distress is categorized as a severe corner break.

B-13.2 Severity Levels.

L Slab is broken into four or five pieces predominantly defined by low-severity cracks.

M (1) Slab is broken into four or five pieces, with over 15 percent of the cracks of medium severity (no high-severity cracks); or (2) slab is broken into six or more pieces, with over 85 percent of the cracks of low severity.

H At this level of severity, the slab is called shattered: (1) slab is broken into four or five pieces, with some or all of the cracks of high severity; (2) slab is broken into six or more pieces, with over 15 percent of the cracks of medium or high severity.

B-13.3 How to Count.

No other distress such as scaling, spalling, or durability cracking is recorded if the distress is medium- or high-severity level since the severity of this distress substantially affects the slab's rating. Shrinkage cracks are not counted in determining whether or not the slab is broken into four or more pieces.

Figure B-33 Low-Severity Shattered Slab/Intersecting Cracks



Figure B-34 Medium-Severity Shattered Slab/Intersecting Cracks



Figure B-35 High-Severity Shattered Slab/Intersecting Cracks



B-14 SHRINKAGE CRACKS (73) {13}.

B-14.1 Description.

Shrinkage cracks are hairline cracks that are usually only a few feet (meters) long and do not extend across the entire slab. They are formed during the setting and curing of the concrete and usually do not extend through the depth of the slab.

B-14.2 Severity Levels.

No degrees of severity are defined. It is sufficient to indicate that shrinkage cracks exist.

B-14.3 How to Count.

If one or more shrinkage cracks exist on one particular slab, the slab is counted as one slab with shrinkage cracks.

Figure B-36 Shrinkage Cracks



B-15 JOINT SPALLING (TRANSVERSE AND LONGITUDINAL JOINTS) (74) {14}.

B-15.1 Description.

Joint spalling is the breakdown of the slab edges within 2 feet (600 millimeters) of the side of the joint. A joint spall usually does not extend vertically through the slab but intersects the joint at an angle. Spalling results from excessive stresses at the joint or crack caused by infiltration of incompressible materials or traffic loads. Weak concrete at the joint (caused by overworking) combined with traffic loads also causes spalling.

Frayed condition as used in the test method in the following table indicates that material is no longer in place along a joint or crack. Spalling indicates material may or may not be missing along a joint or crack.

B-15.2 Severity Levels.

Table B-3 Severity Levels of Spalling

	Spall Length	Description
L	< 2 feet (600 mm)	Spall is broken into pieces or fragmented; little FOD or tire damage potential exists.
	> 2 feet (600 mm)	(a) Spall is broken into no more than three pieces defined by low- or medium-severity cracks; little or no FOD potential exists; or (b) joint is lightly frayed; little or no FOD potential exists.
M	< 2 feet (600 mm)	Spall is broken into pieces or fragmented, with some of the pieces loose or absent, causing considerable FOD or tire damage potential.
	> 2 feet (600 mm)	(a) Spall is broken into more than three pieces defined by light or medium cracks; (b) spall is broken into no more than three pieces, with one or more of the cracks being severe, with some FOD potential existing; or (c) joint is moderately frayed, with some FOD potential.
H	> 2 feet (600 mm)	(1) Spall is broken into more than three pieces defined by one or more high-severity cracks with high FOD potential; or (2) joint is severely frayed, with high FOD potential.

B-15.3 How to Count.

If the joint spall is located along the edge of one slab, it is counted as one slab with joint spalling. If spalling is located on more than one edge of the same slab, the edge having the highest severity is counted and recorded as one slab. Joint spalling can also occur along the edges of two adjacent slabs. If this is the case, each slab is counted as having joint spalling. If a joint spall is small enough to be filled during a joint seal repair, it is not recorded.

Figure B-37 Low-Severity Joint Spall



Figure B-38 Medium-Severity Joint Spall



Figure B-39 High-Severity Joint Spall



Figure B-40 High-Severity Joint Spall



B-16 SPALLING (CORNER) (75) {15}.

B-16.1 Description.

Corner spalling is the raveling or breakdown of the slab within approximately 2 feet (600 millimeters) of the corner. A corner spall differs from a corner break in that the spall angles downward to intersect the joint, while a break extends vertically through the slab.

B-16.2 Severity Levels.

L One of these conditions exists: (1) spall is broken into one or two pieces defined by low-severity cracks (little or no FOD potential); or (2) spall is defined by one medium-severity crack (little or no FOD potential).

M One of these conditions exists: (1) spall is broken into two or more pieces defined by one or more medium-severity cracks and a few small fragments may be absent or loose; (2) spall is defined by one severe, fragmented crack that may be accompanied by a few hairline cracks; or (3) spall has deteriorated to the extent that loose material is causing some FOD potential.

H One of these conditions exists: (1) spall is broken into two or more pieces defined by one or more high-severity fragmented cracks, with loose or absent fragments; (2) pieces of the spall have been displaced to the extent that a tire damage hazard exists; or (3) spall has deteriorated to the extent that loose material is causing high FOD potential.

B-16.3 How to Count.

If one or more corner spalls having the same severity level are located in a slab, the slab is counted as one slab with corner spalling. If more than one severity level occurs, it is counted as one slab having the higher severity level.

A corner spall smaller than 3 inches (76 millimeters) wide, measured from the edge of the slab and filled with sealant, is not recorded.

Figure B-41 Low-Severity Corner Spall



Figure B-42 Medium-Severity Corner Spall



Figure B-43 High-Severity Corner Spall

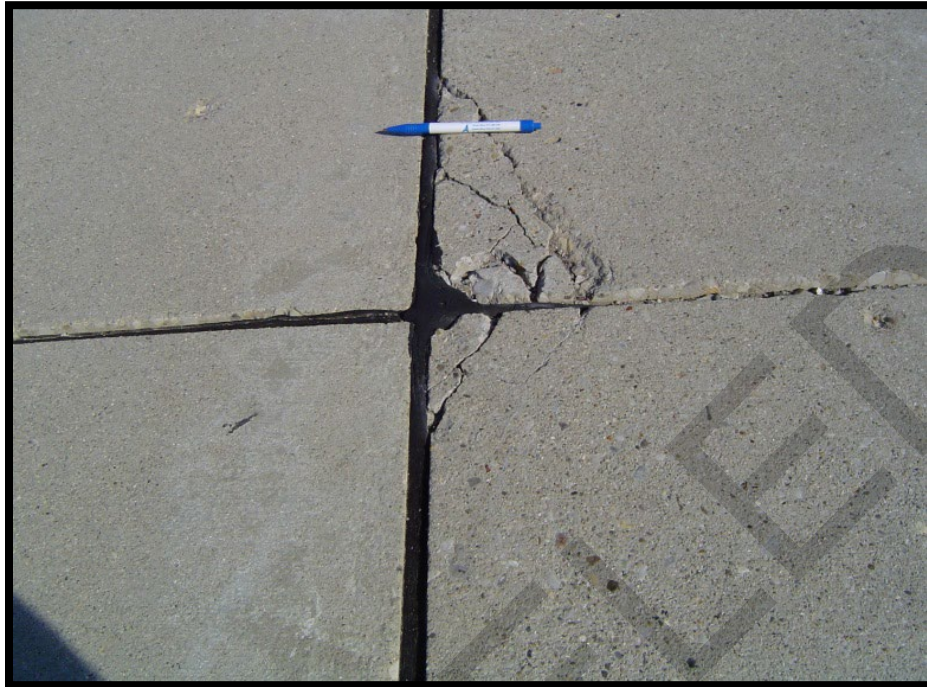

B-17 ALKALI-SILICA REACTION (ASR) (76) {16}.

B-17.1 Description.

ASR is caused by a chemical reaction between alkalis and certain reactive silica minerals, which form a gel. The gel absorbs water, causing expansion that may damage the concrete and adjacent structures. Alkalis are most often introduced by the portland cement within the pavement. ASR cracking may be accelerated by chemical pavement deicers. Visual indicators that ASR is present include:

- Cracking of the concrete pavement (often in a map pattern)
- White, brown, gray, or other colored gel or staining possibly present at the crack surface
- Aggregate popouts
- Increase in concrete volume (expansion) that may result in distortion of adjacent or integral structures or physical elements. Examples of expansion include shoving of asphalt pavements, light can tilting, slab faulting, joint misalignment, and extrusion of joint seals or expansion joint fillers.

Because ASR is material-dependent, it is generally present throughout the pavement section. Coring and concrete petrographic analysis is the only definitive method to confirm ASR. Keep these factors in mind when identifying the presence of ASR through visual inspection:

- Generally, ASR distresses are not observed in the first few years after construction. In contrast, plastic shrinkage cracking can occur the day of construction and is apparent within the first year.
- ASR is differentiated from D-cracking by the presence of cracking perpendicular to the joint face. D-cracking predominantly develops as a series of parallel cracks to joint faces and linear cracking within the slab.
- ASR is differentiated from map cracking/scaling by the presence of visual signs of expansion.

B-17.2 Severity Levels.

L Minimal to no FOD potential from cracks, joints, or ASR-related popouts; cracks at the surface are tight (predominantly 0.04 inch [1 millimeter] or less). Little to no evidence of movement in pavement or surrounding structures or elements.

M Some FOD potential; increased sweeping or other FOD removal methods may be required; there may be evidence of slab movement and/or some damage to adjacent structures or elements. Medium ASR distress is differentiated from low by having one or more of the following: increased FOD potential, increased cracking of the slab, some fragments along cracks or at crack intersections, possible surface popouts of concrete, pattern of wider cracks (predominantly 0.04 inch [1 millimeter] or wider) that may be subdivided by tighter cracks.

H One or both of these conditions exists: (1) loose or missing concrete fragments that pose high FOD potential; (2) slab surface integrity and function significantly degraded and pavement requires immediate repair; may also require repairs to adjacent structures or elements.

B-17.3 How to Count.

No other distresses are recorded if high-severity ASR is recorded.

Figure B-44 Low-Severity ASR

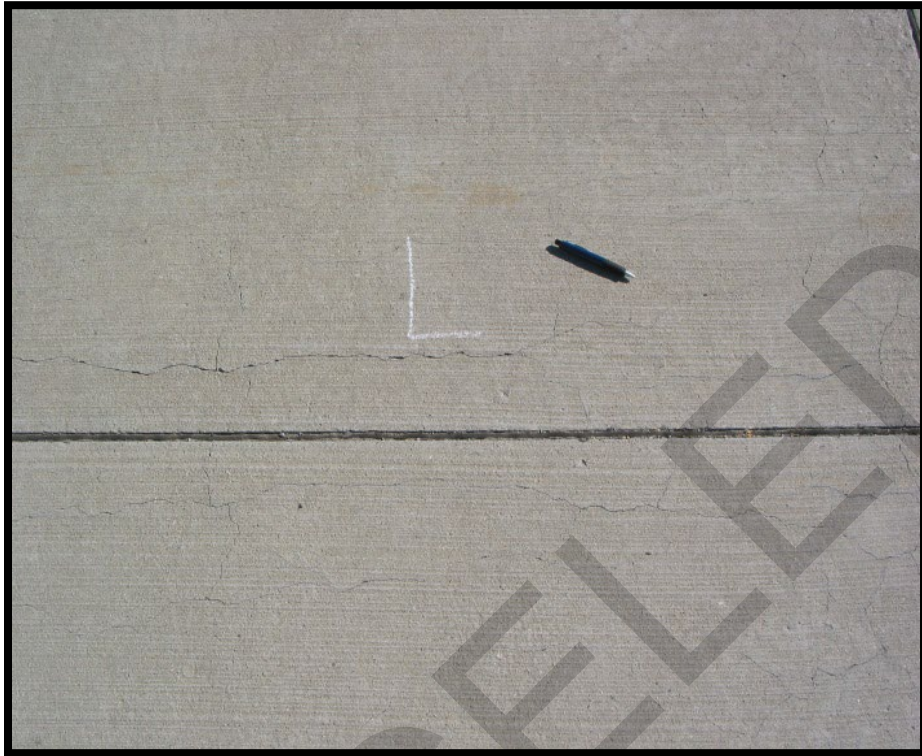

Figure B-45 Medium-Severity ASR



Figure B-46 High-Severity ASR



APPENDIX C DEDUCT CURVES FOR ASPHALT (BITUMINOUS) AIRFIELD
PAVEMENTS

Figure C-1 Deduct Curves for Alligator Cracking (41) {1}

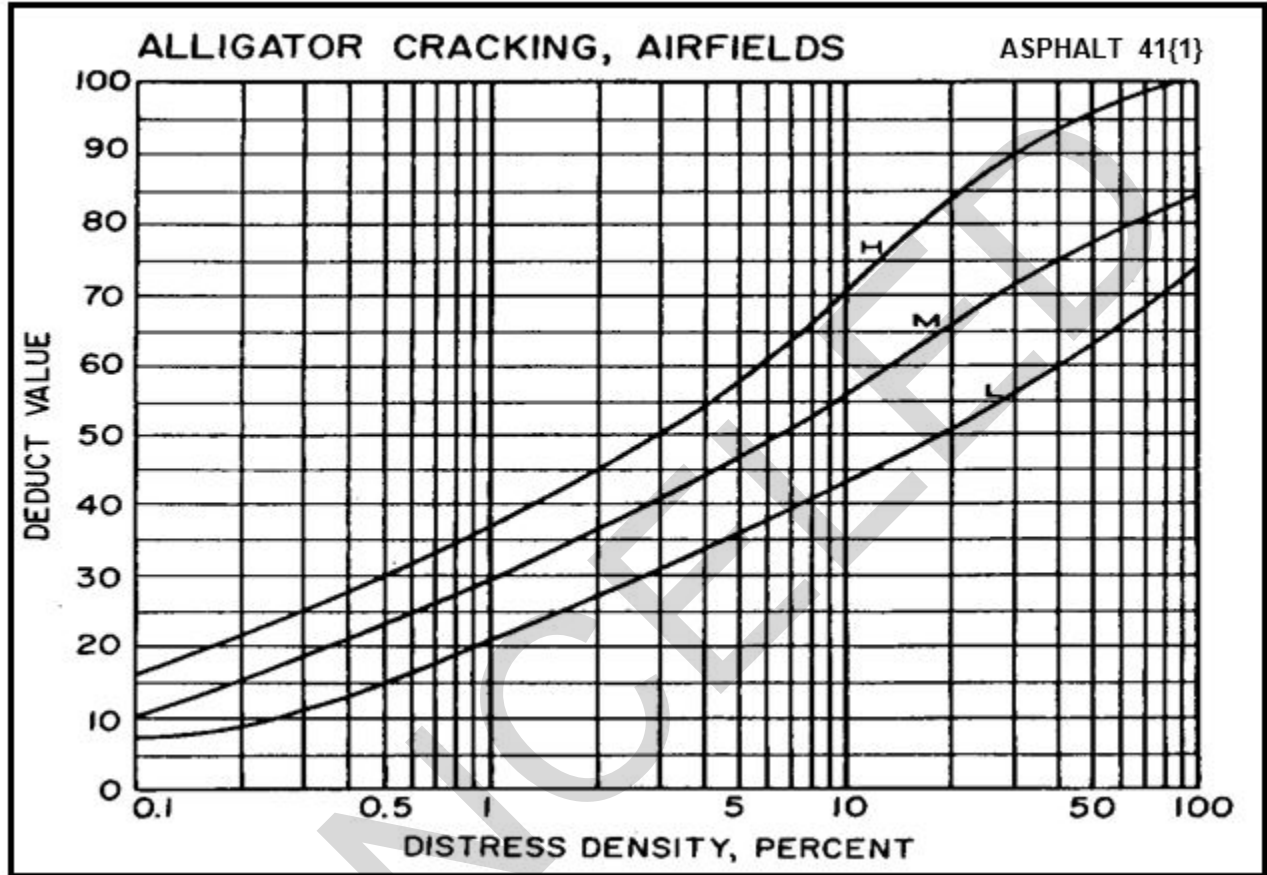

Figure C-2 Deduct Curve for Bleeding (42) {2}

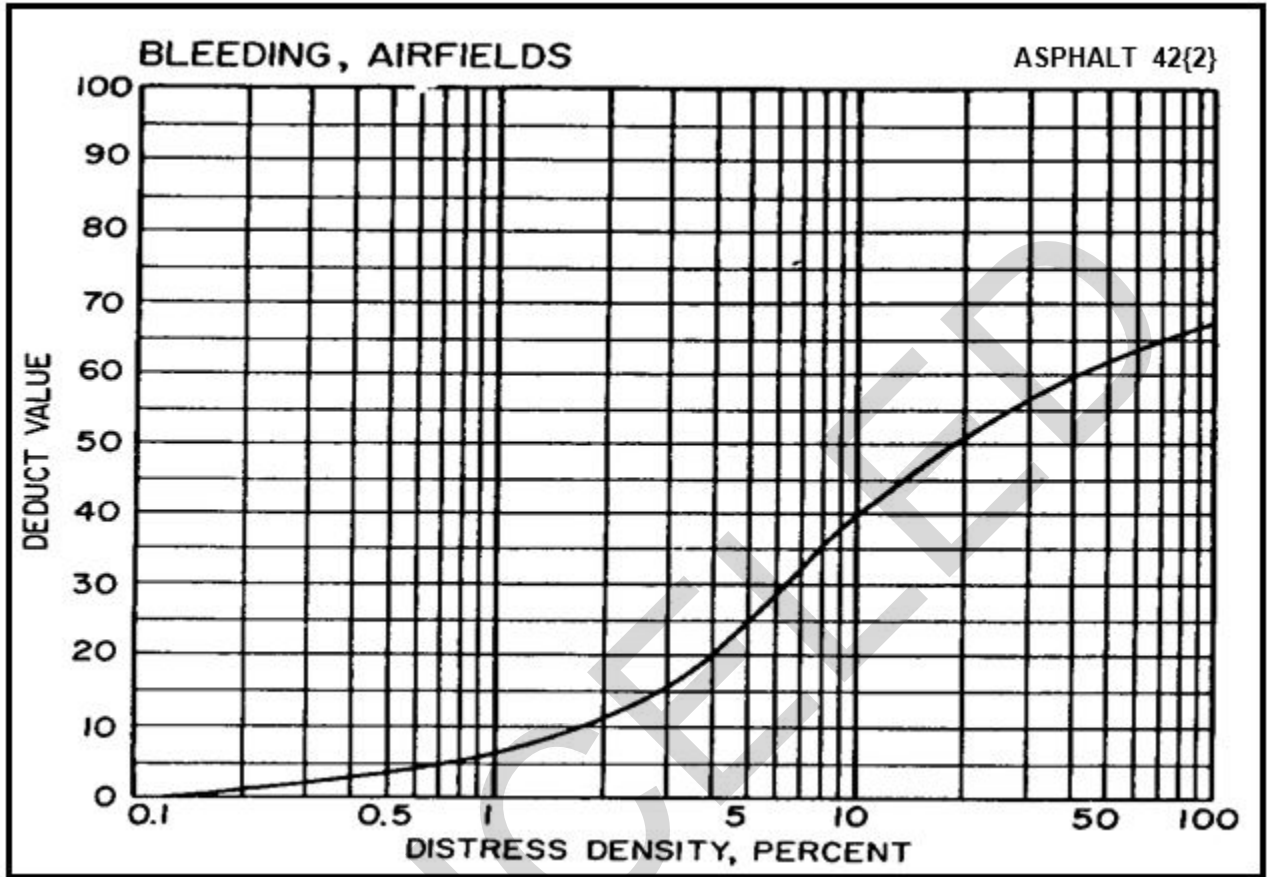

Figure C-3 Deduct Curves for Block Cracking (43) {3}

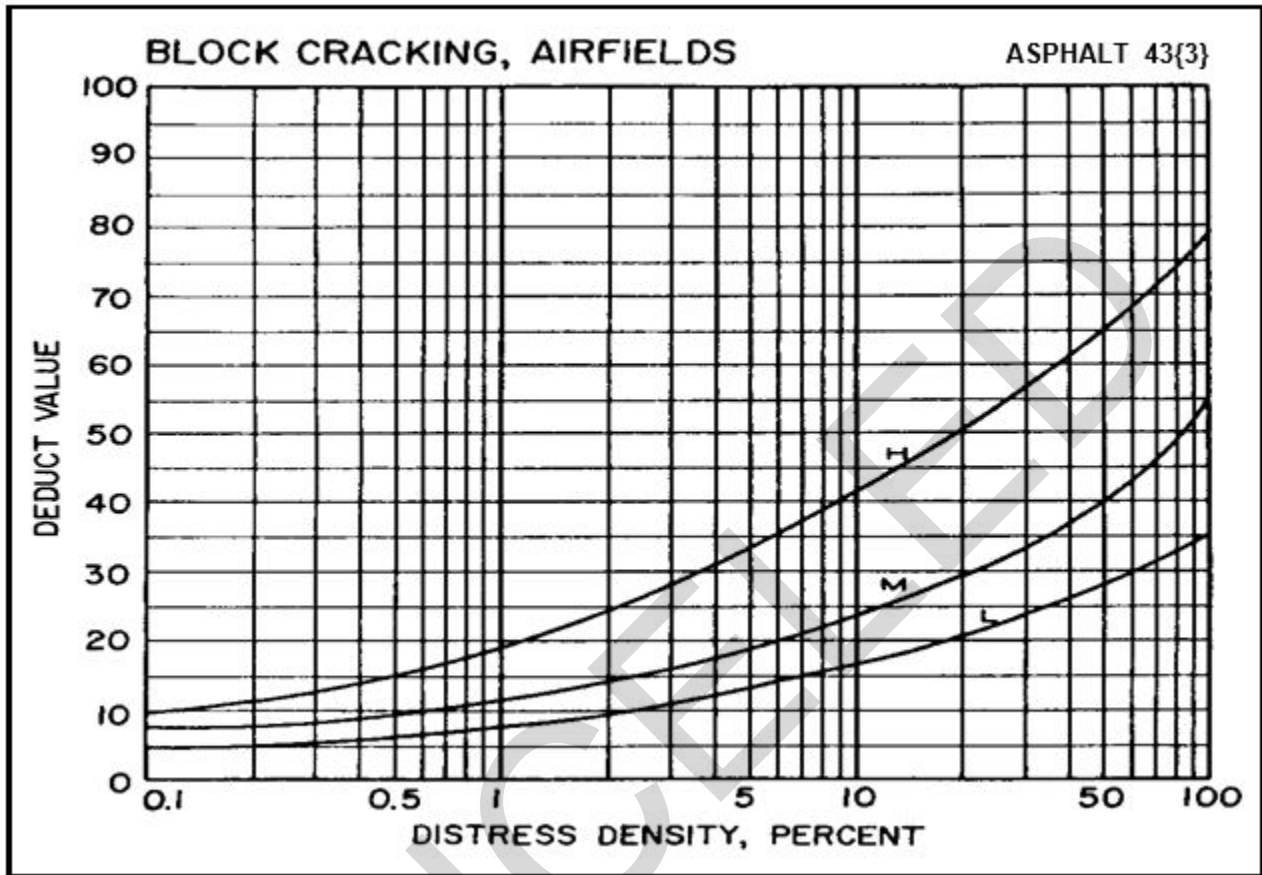

Figure C-4 Deduct Curves for Corrugation (44) {4}

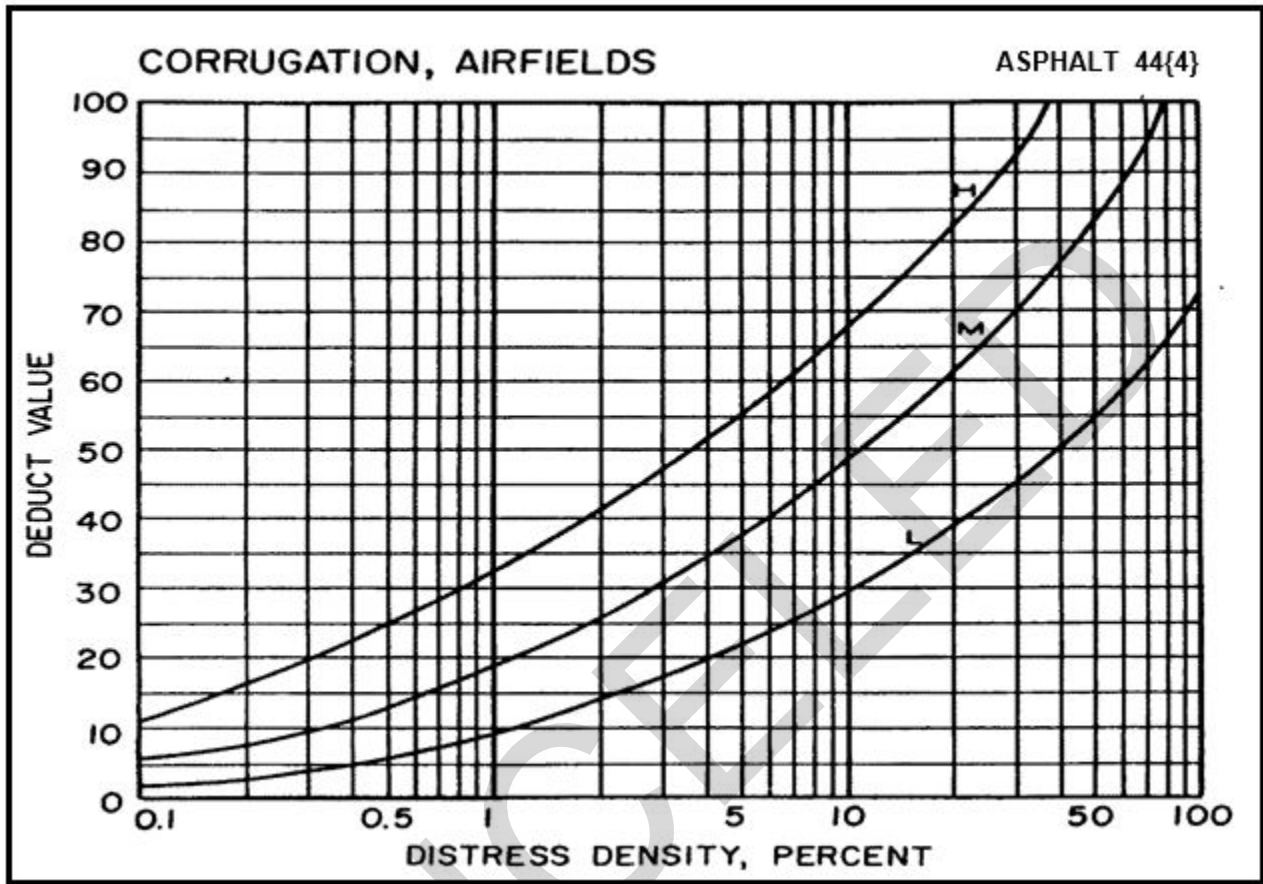

Figure C-5 Deduct Curves for Depression (45) {5}

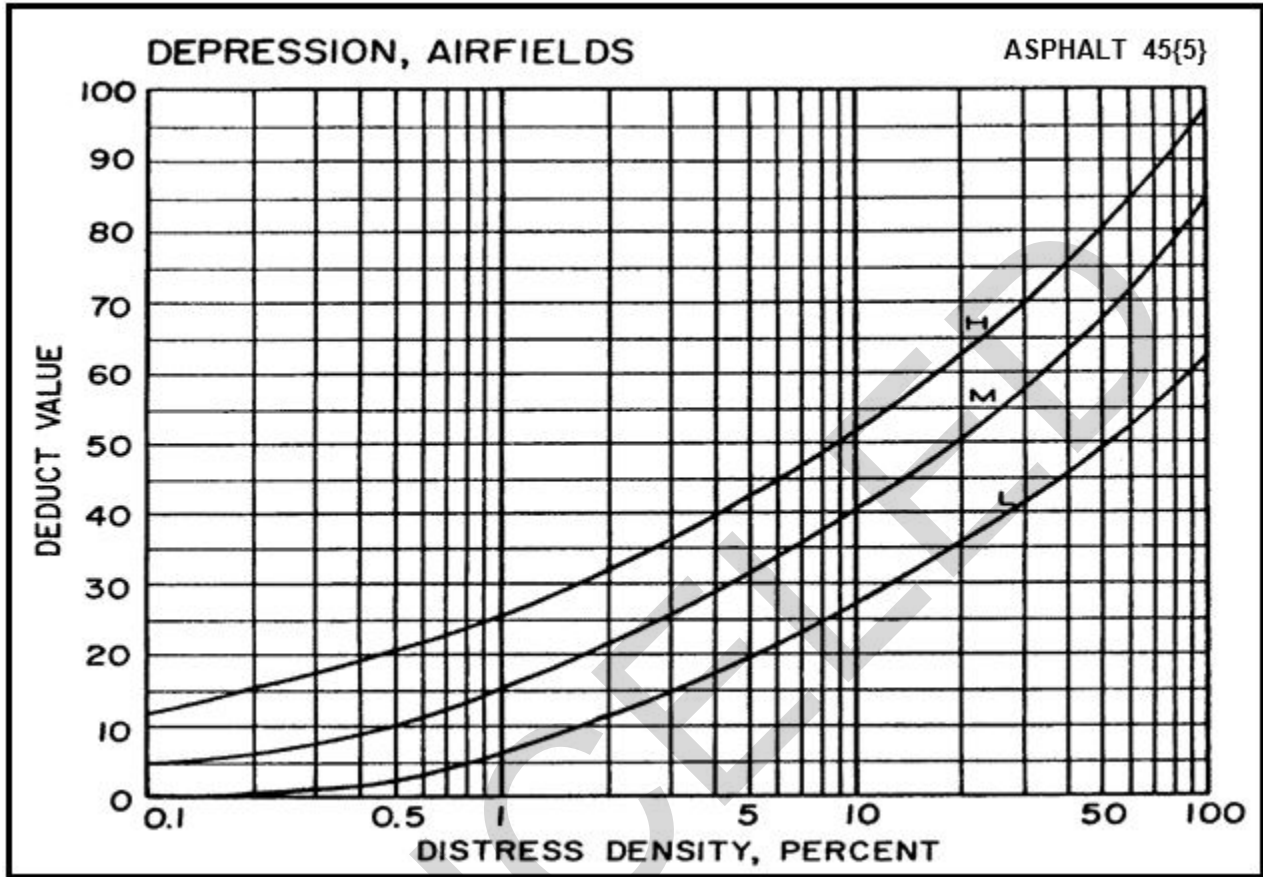

Figure C-6 Deduct Curve for Jet Blast Erosion (46) {6}

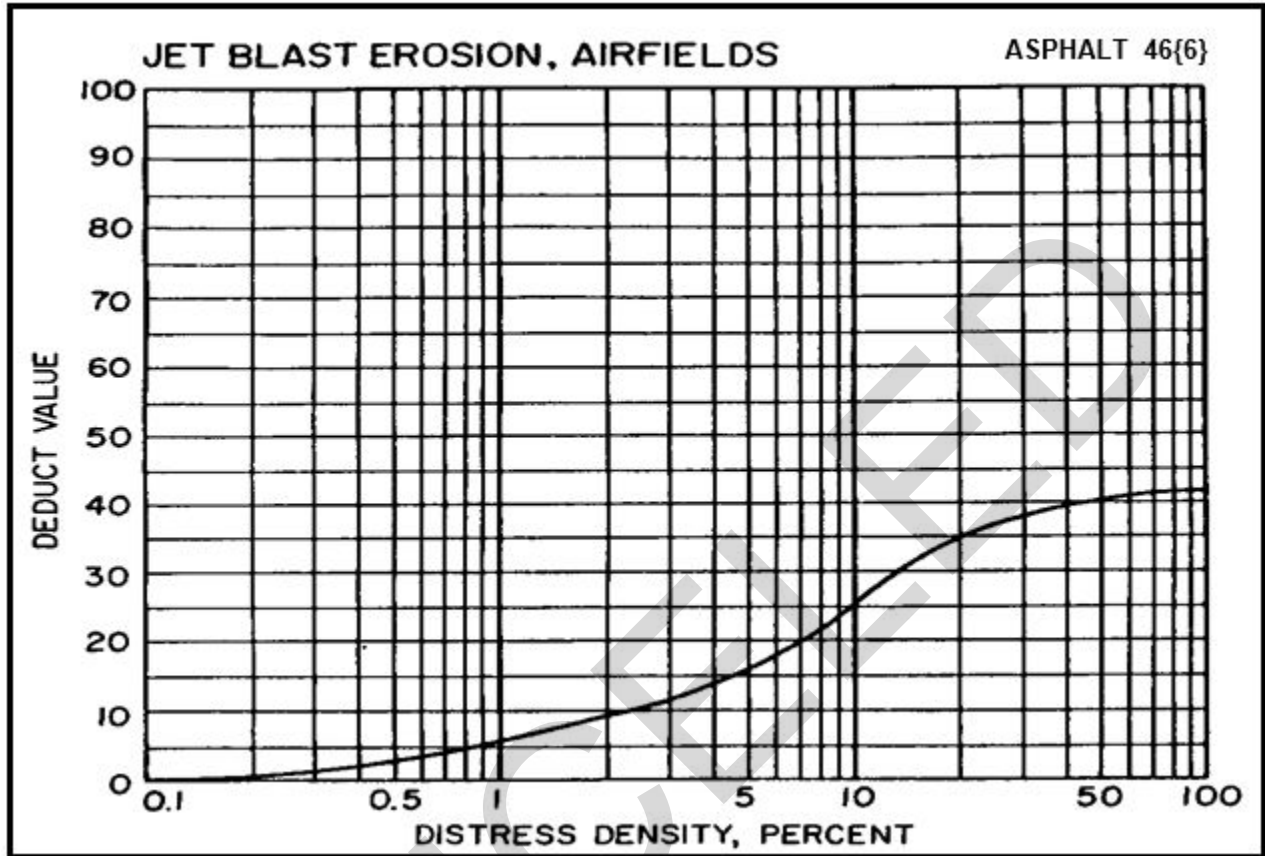

Figure C-7 Deduct Curves for Joint Reflection Cracking (47- English Units) {7}

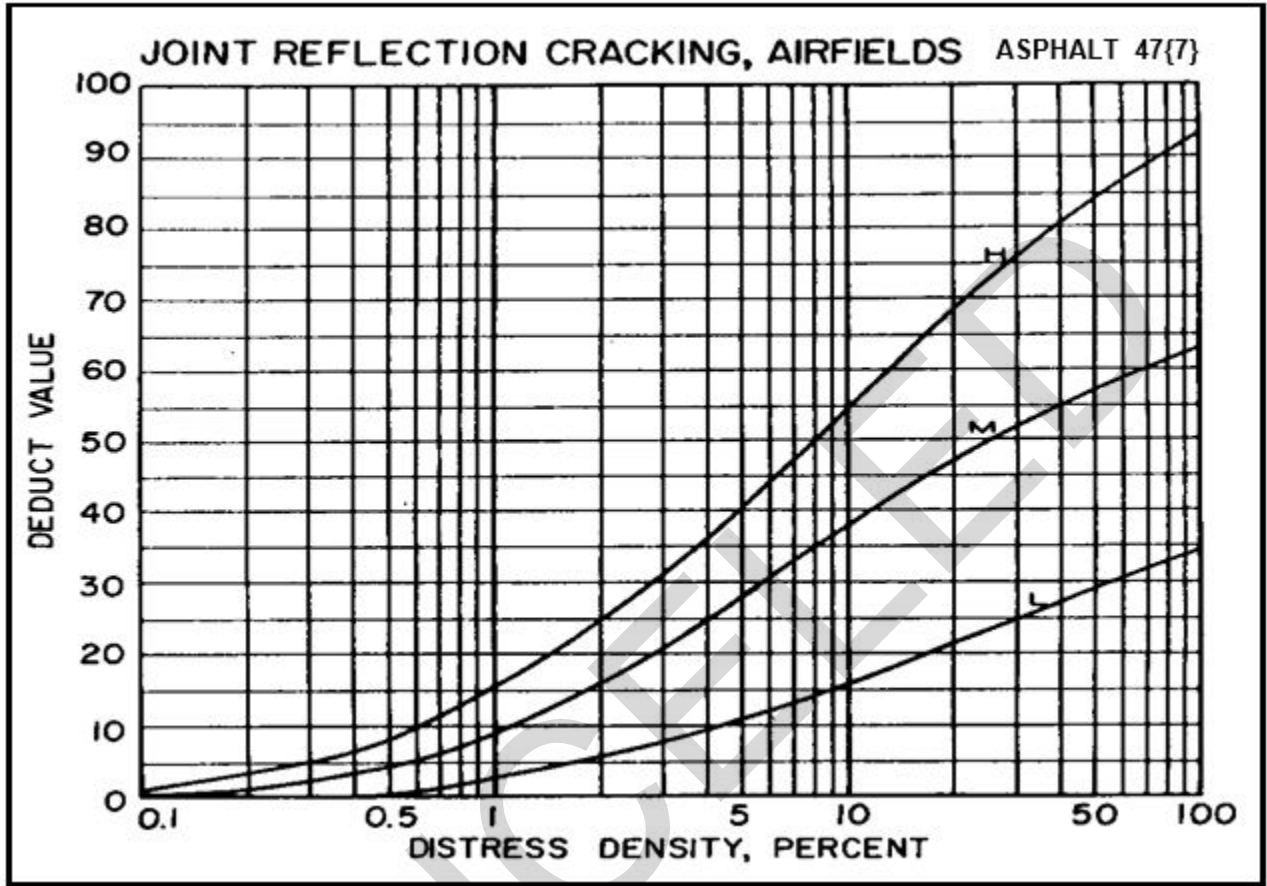

Figure C-8 Deduct Curves for Joint Reflection Cracking (47- Metric Units) {7}

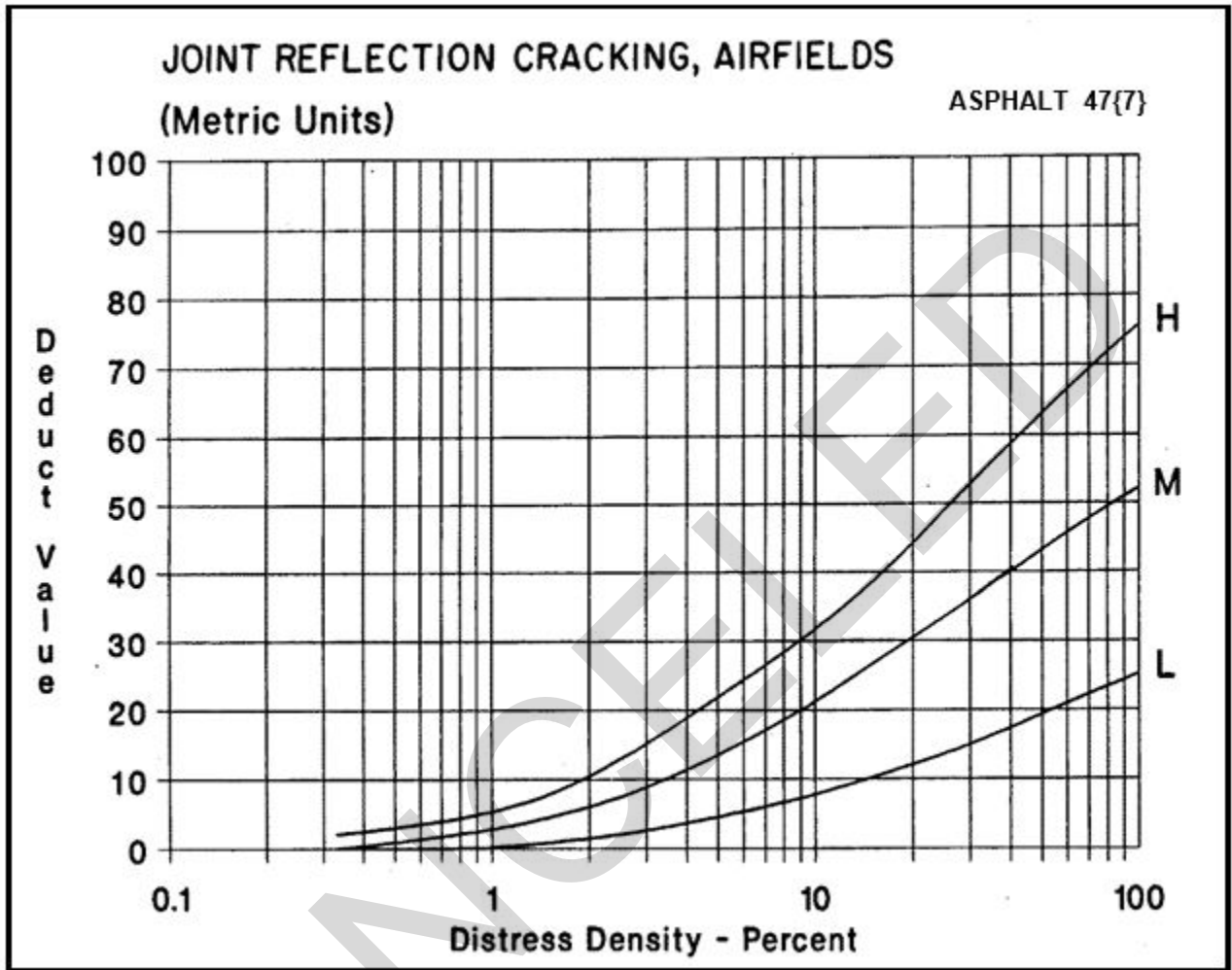

Figure C-9 Deduct Curves for Longitudinal/Transverse (48- English Units) {8}

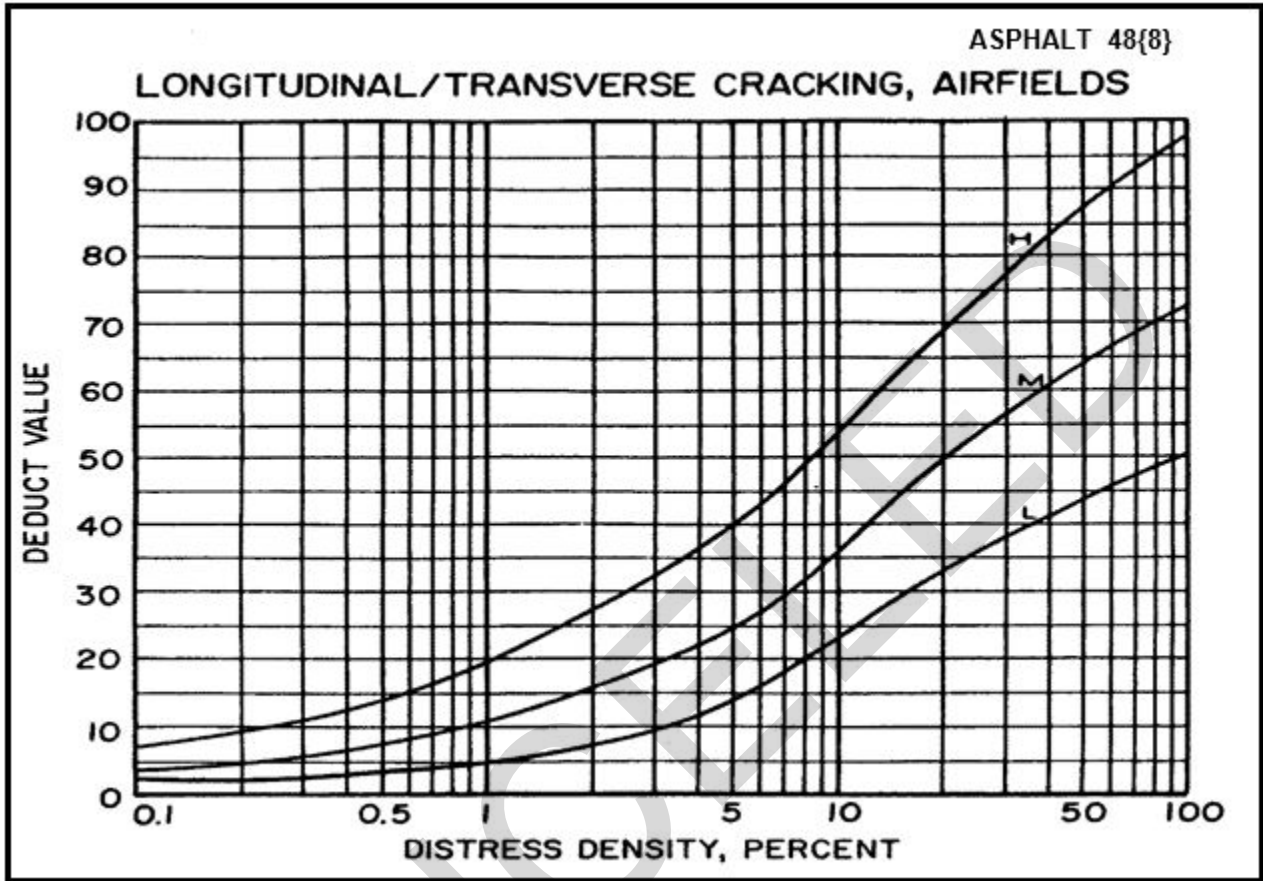

Figure C-10 Deduct Curves for Longitudinal/Transverse (48- Metric Units) {8}

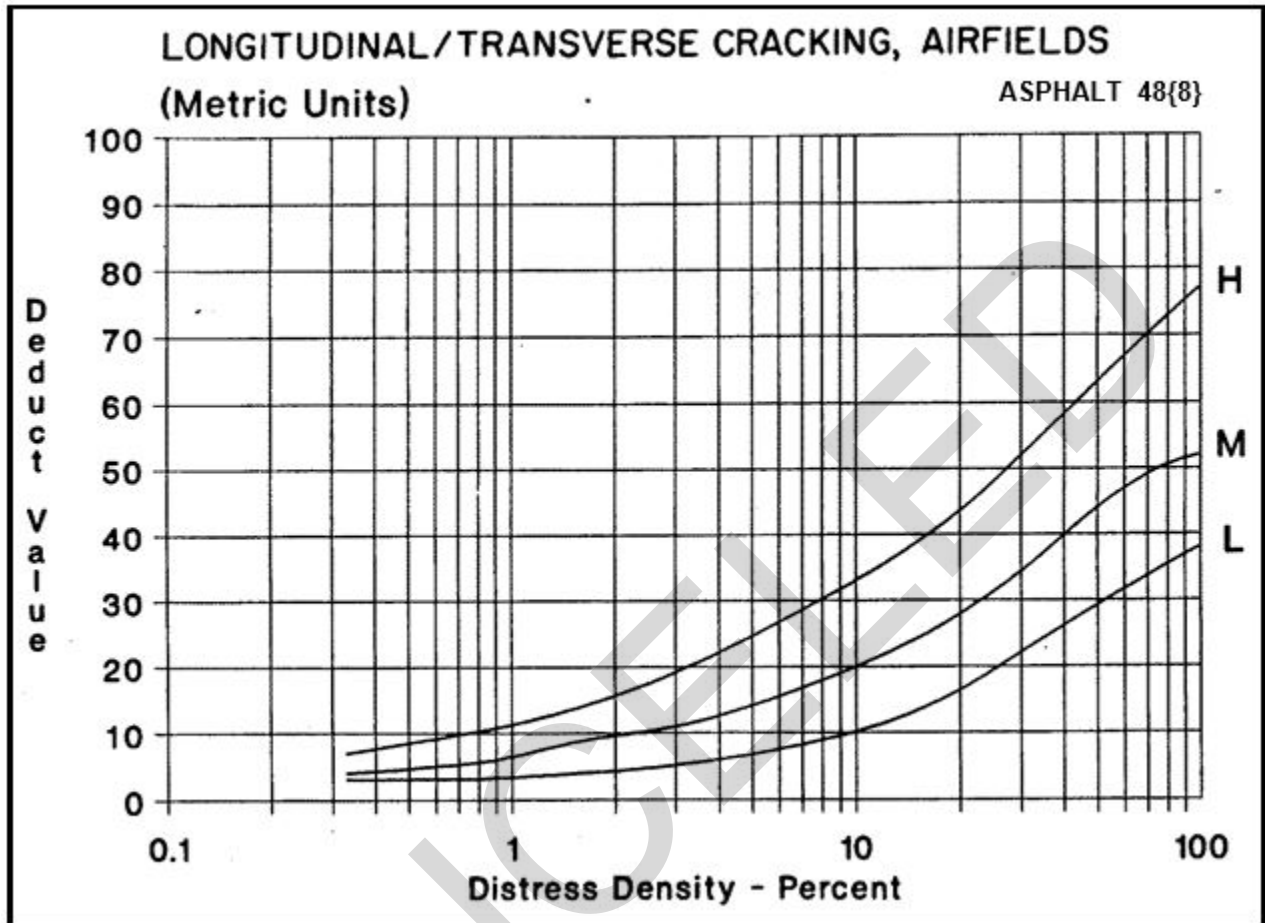

Figure C-11 Deduct Curve for Oil Spillage (49) {9}

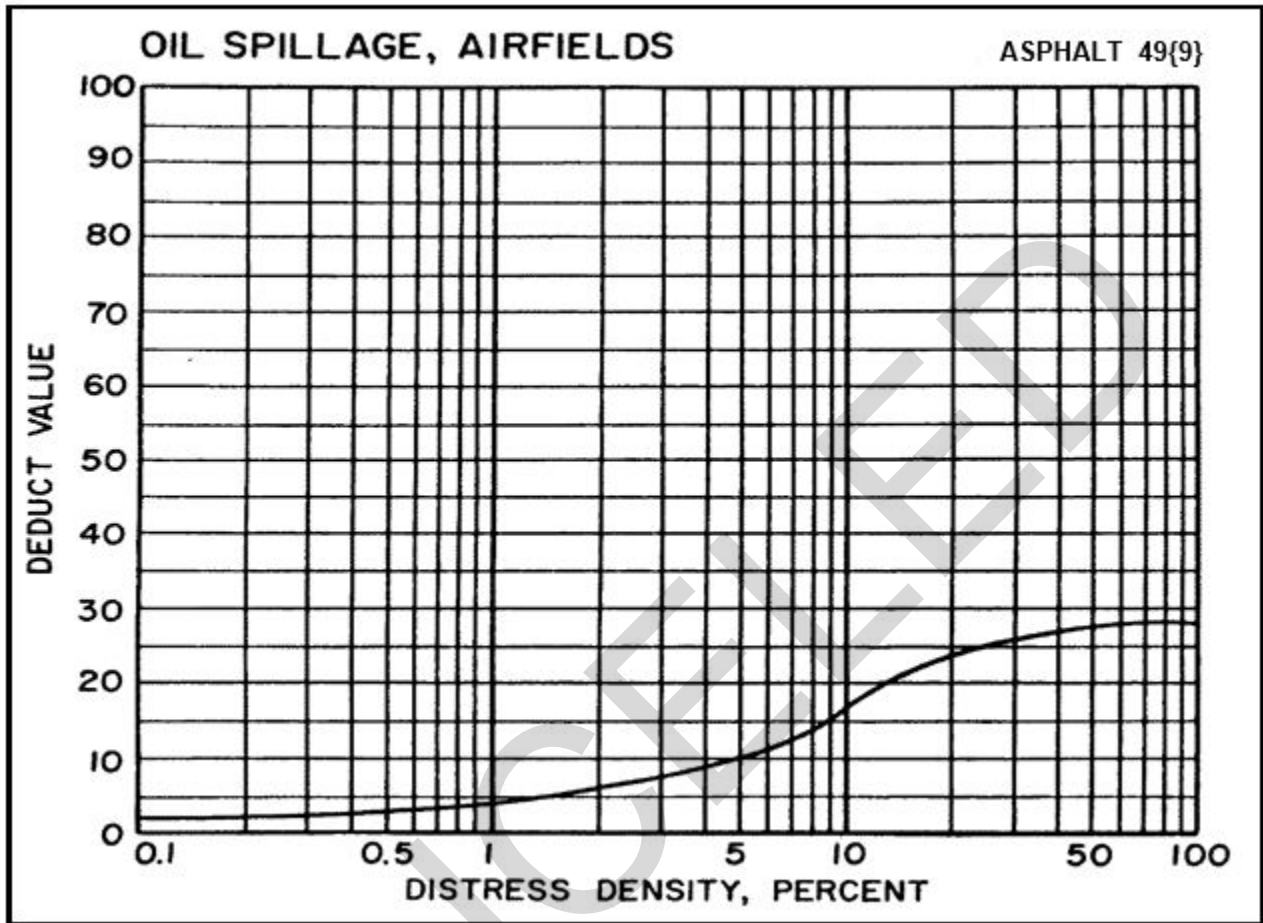

Figure C-12 Deduct Curves for Patching/Utility Cut (50) {10}

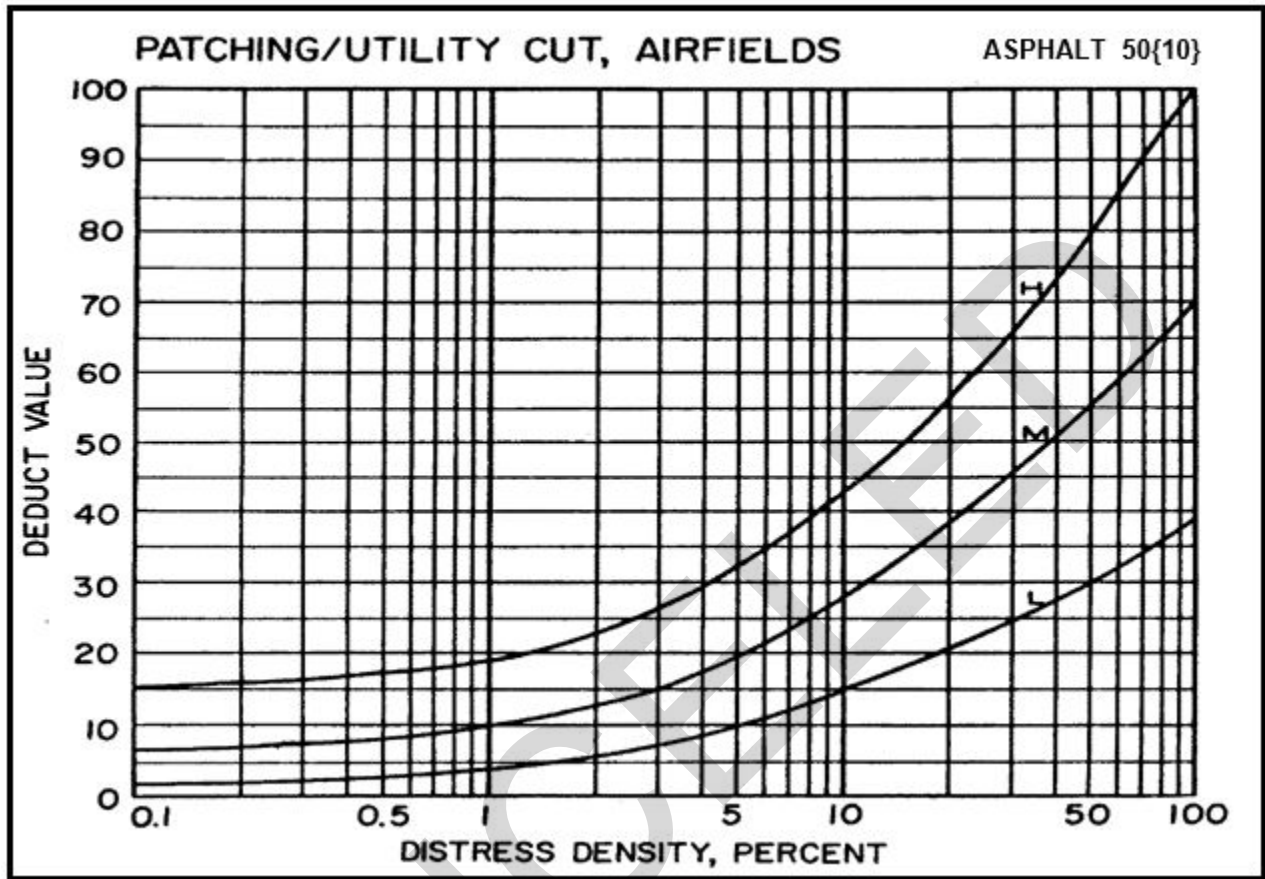

Figure C-13 Deduct Curve for Polished Aggregate (51) {11}

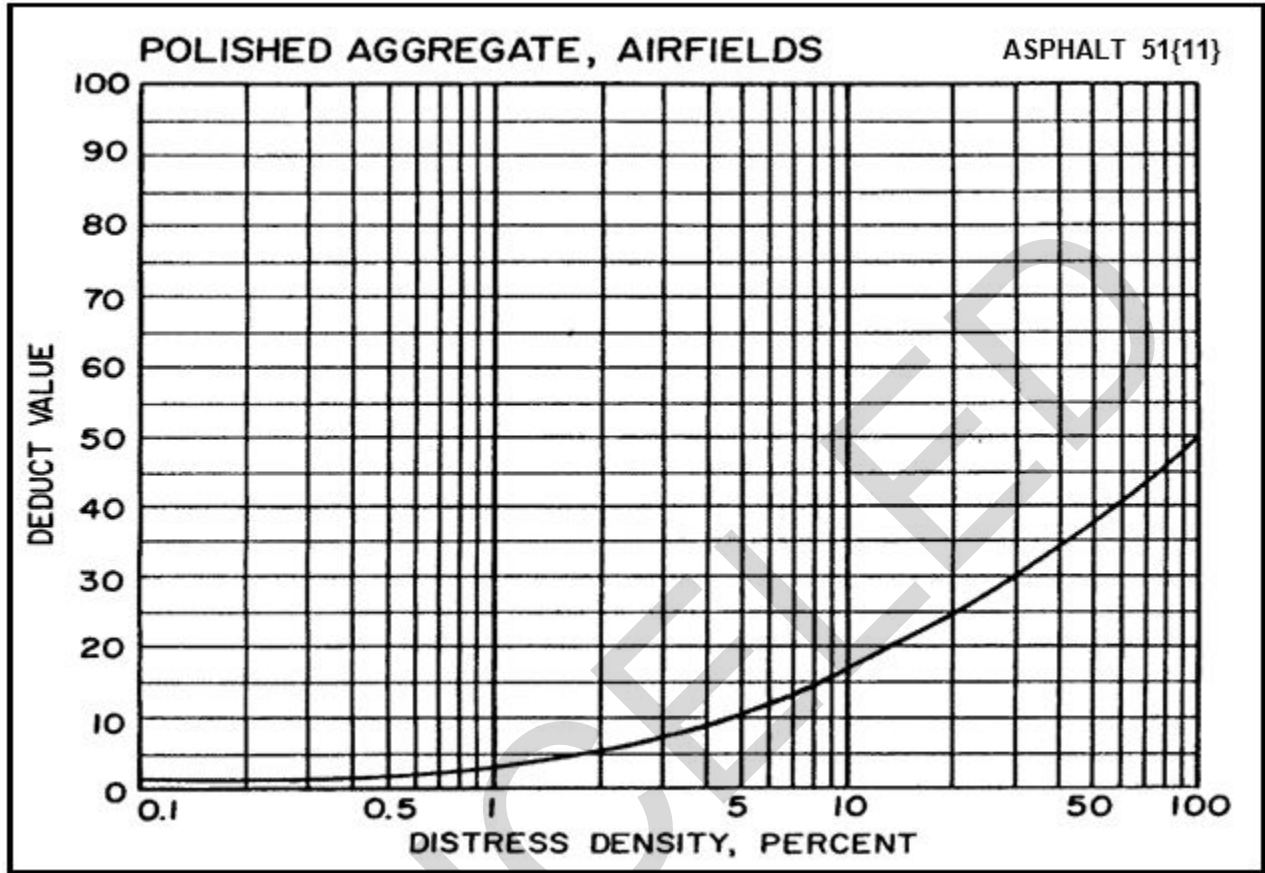

Figure C-14 Deduct Curves for Raveling (52) {12}

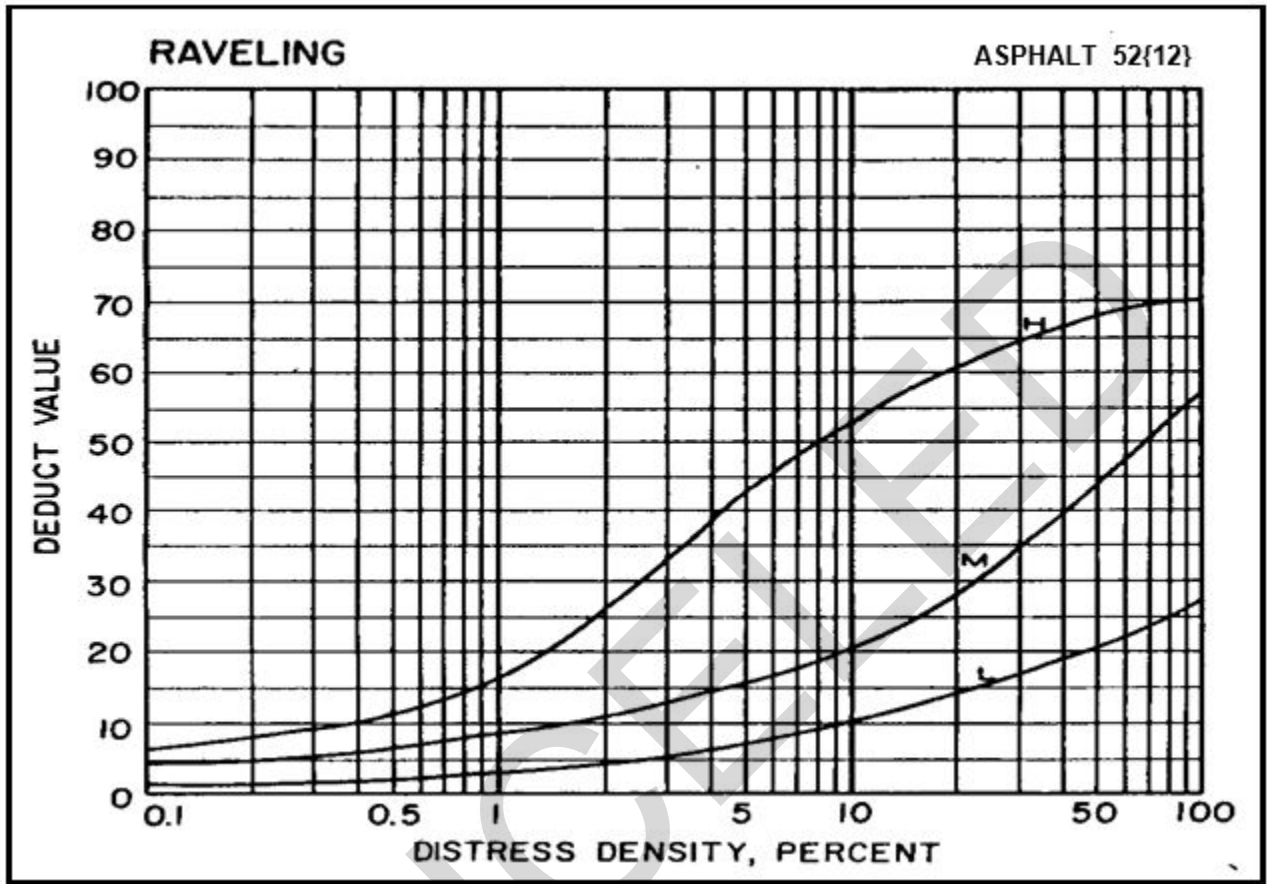

Figure C-15 Deduct Curves for Rutting (53) {13}

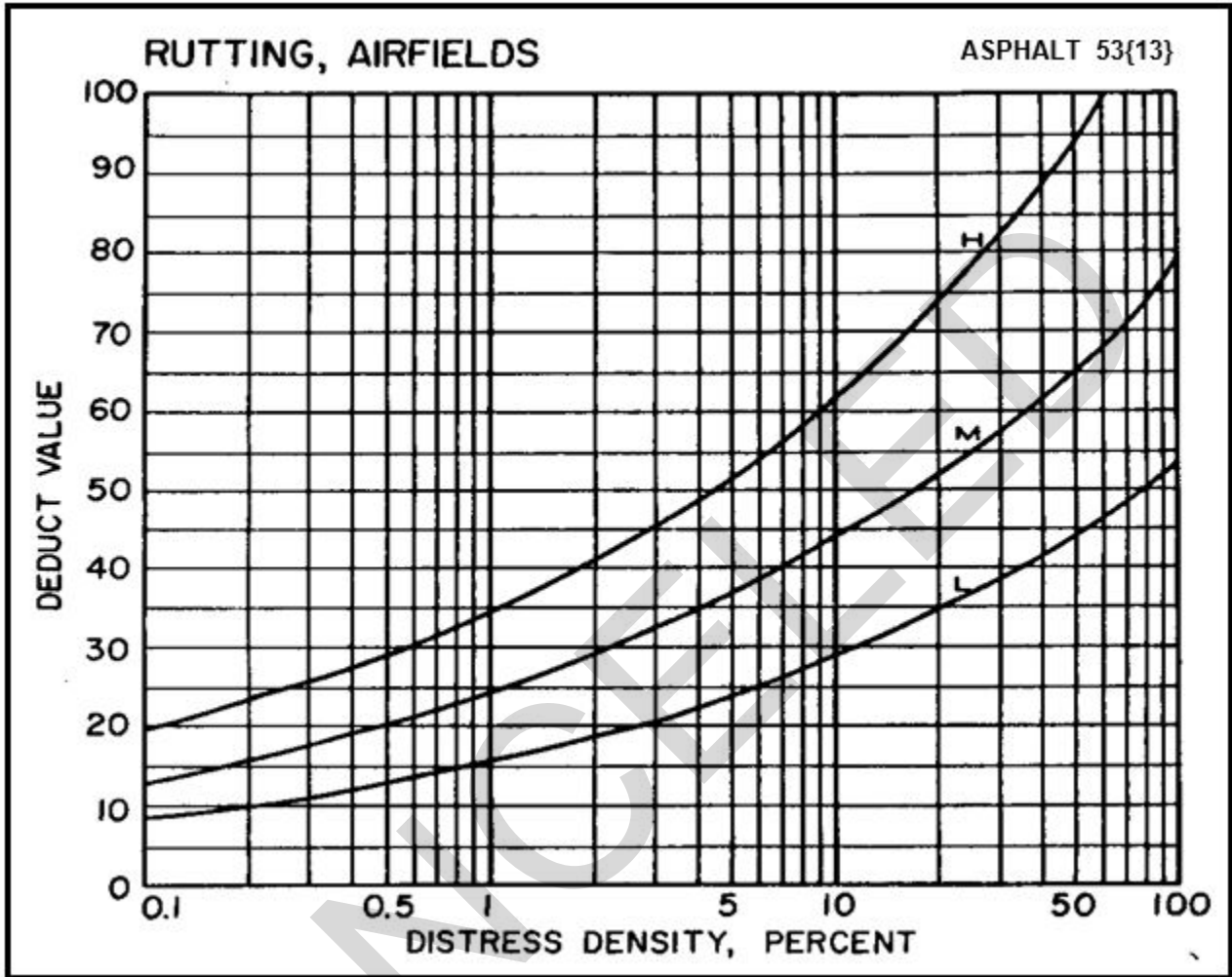

Figure C-16 Deduct Curves for Shoving (54) {14}

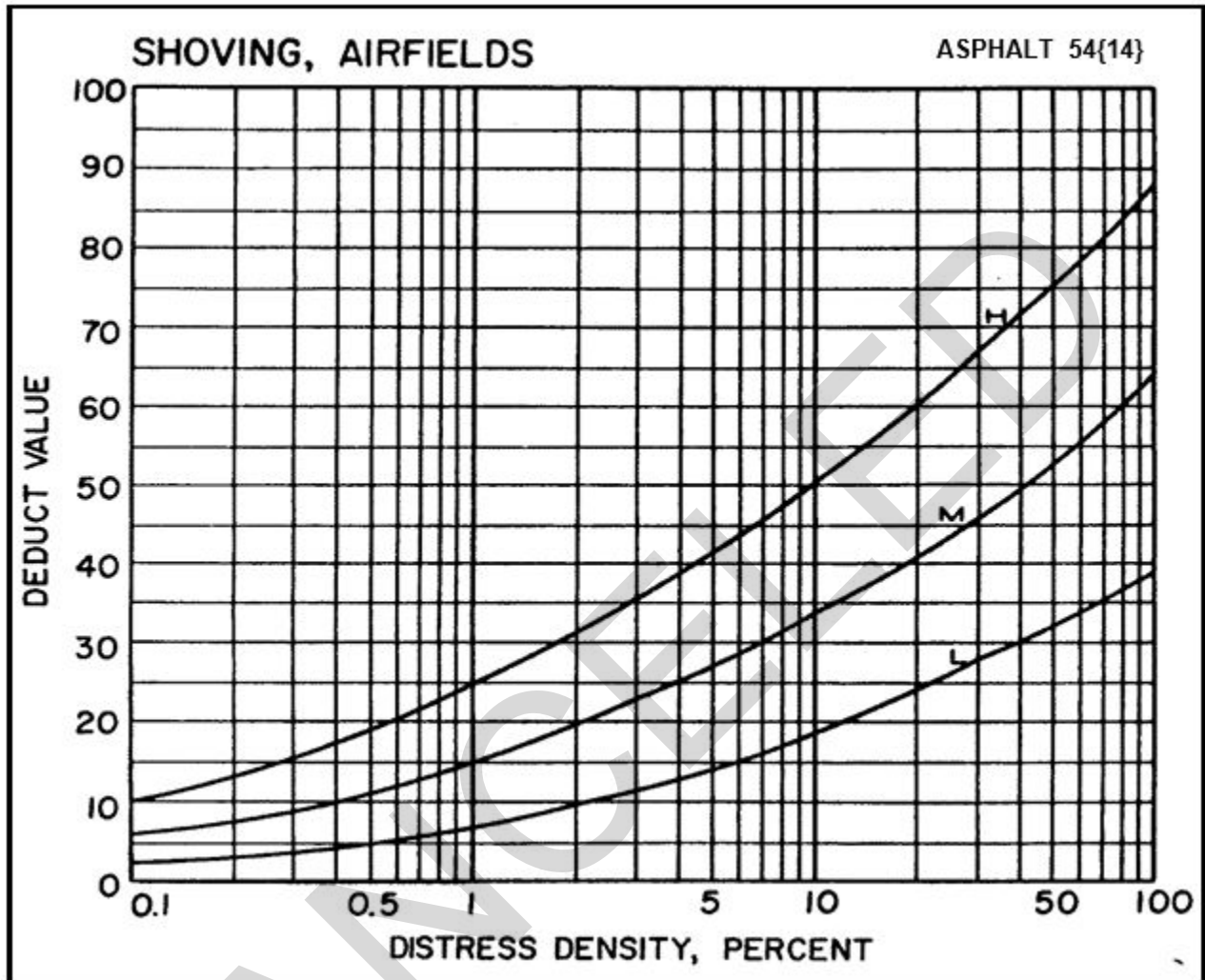

Figure C-17 Deduct Curve for Slippage Cracking (55) {15}

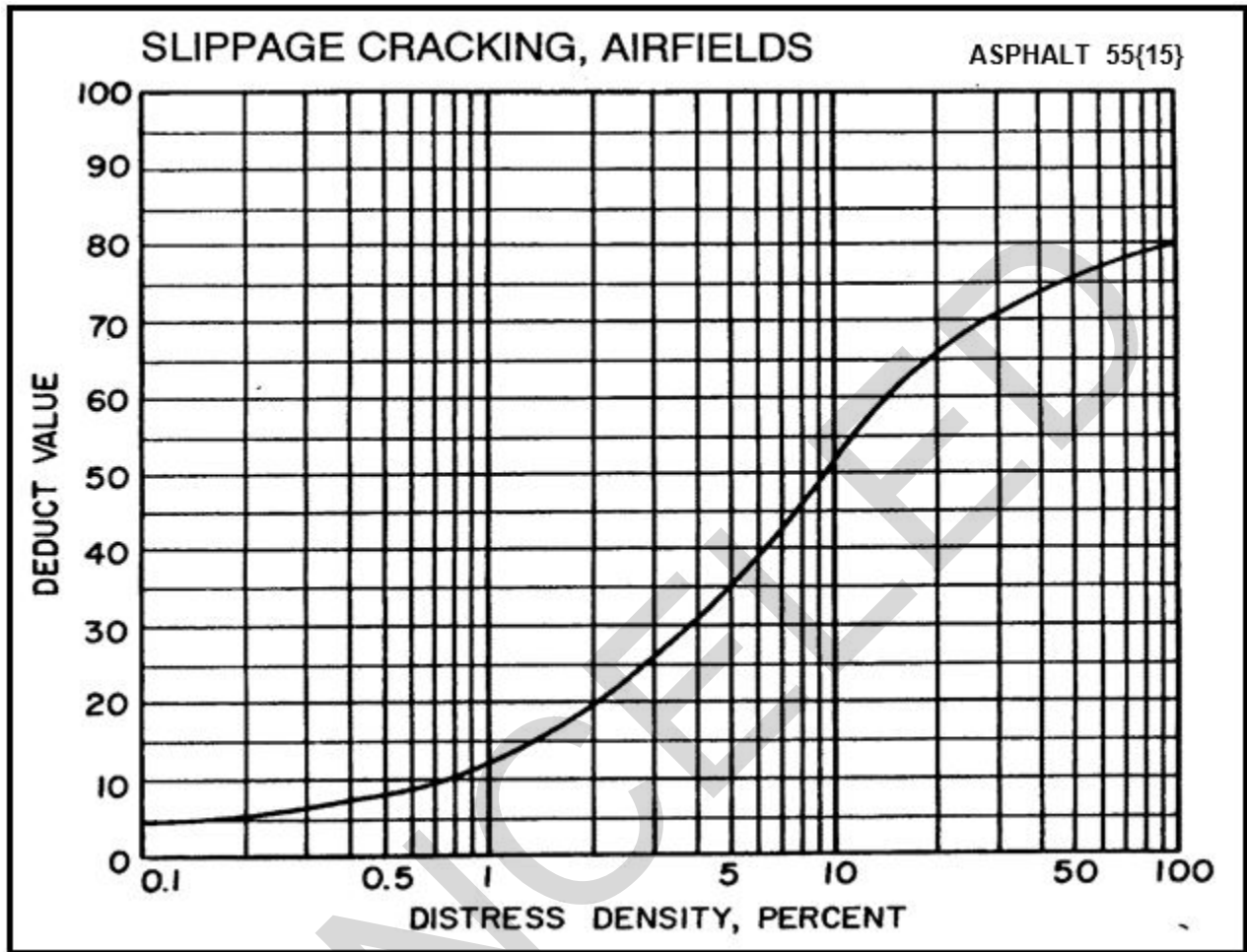

Figure C-18 Deduct Curves for Swell (56) {16}

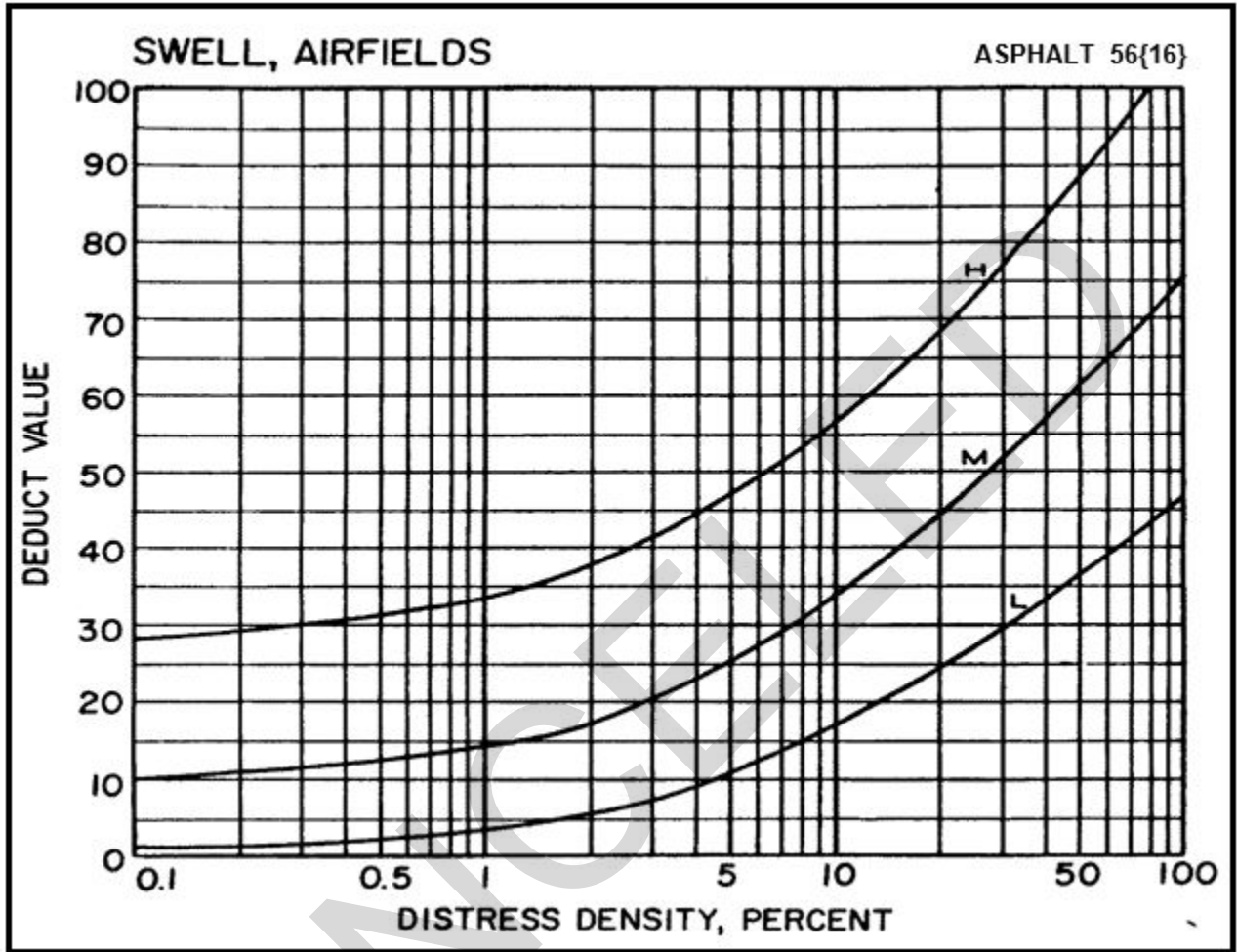

Figure C-19 Deduct Curves for Weathering (57) {17}

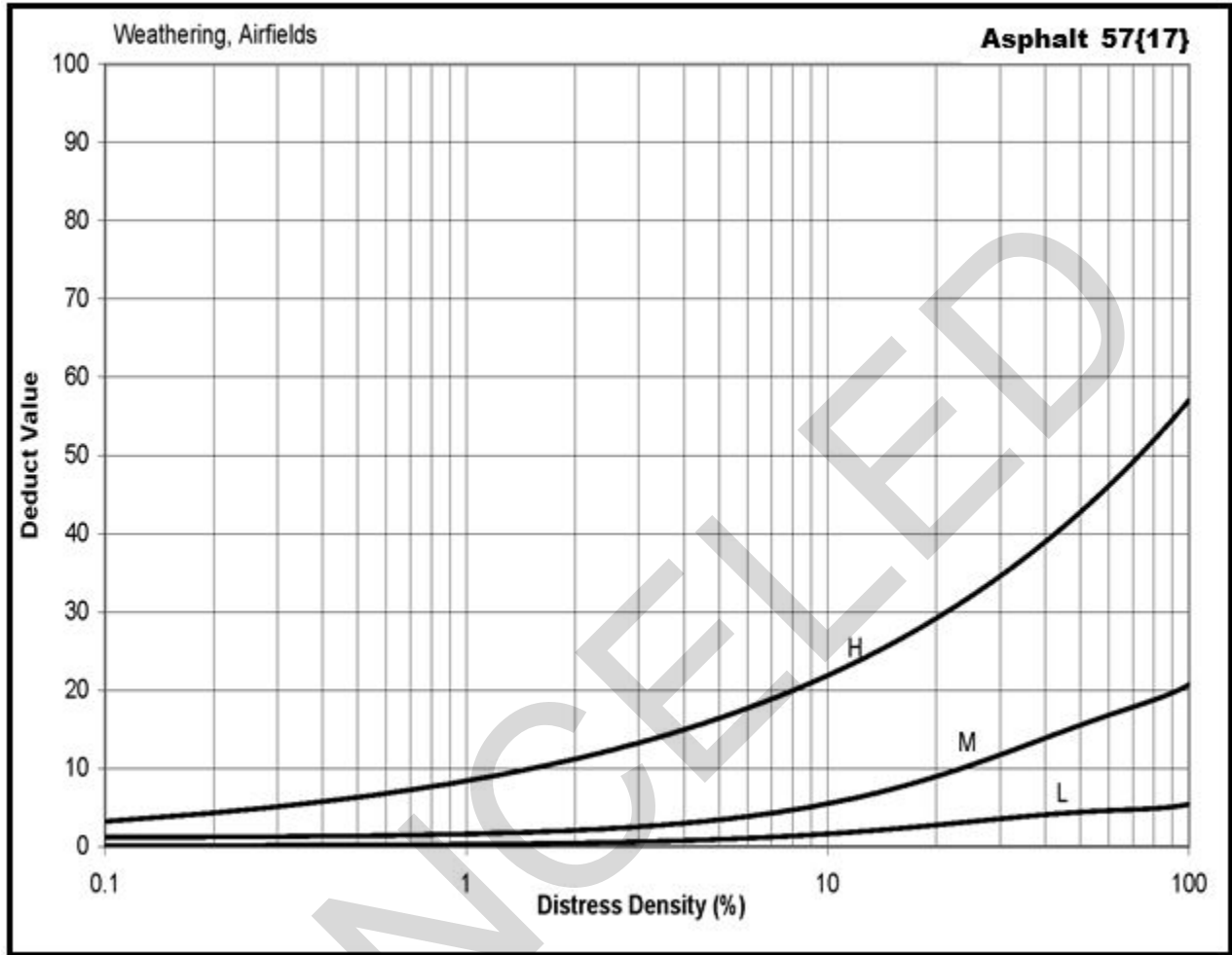
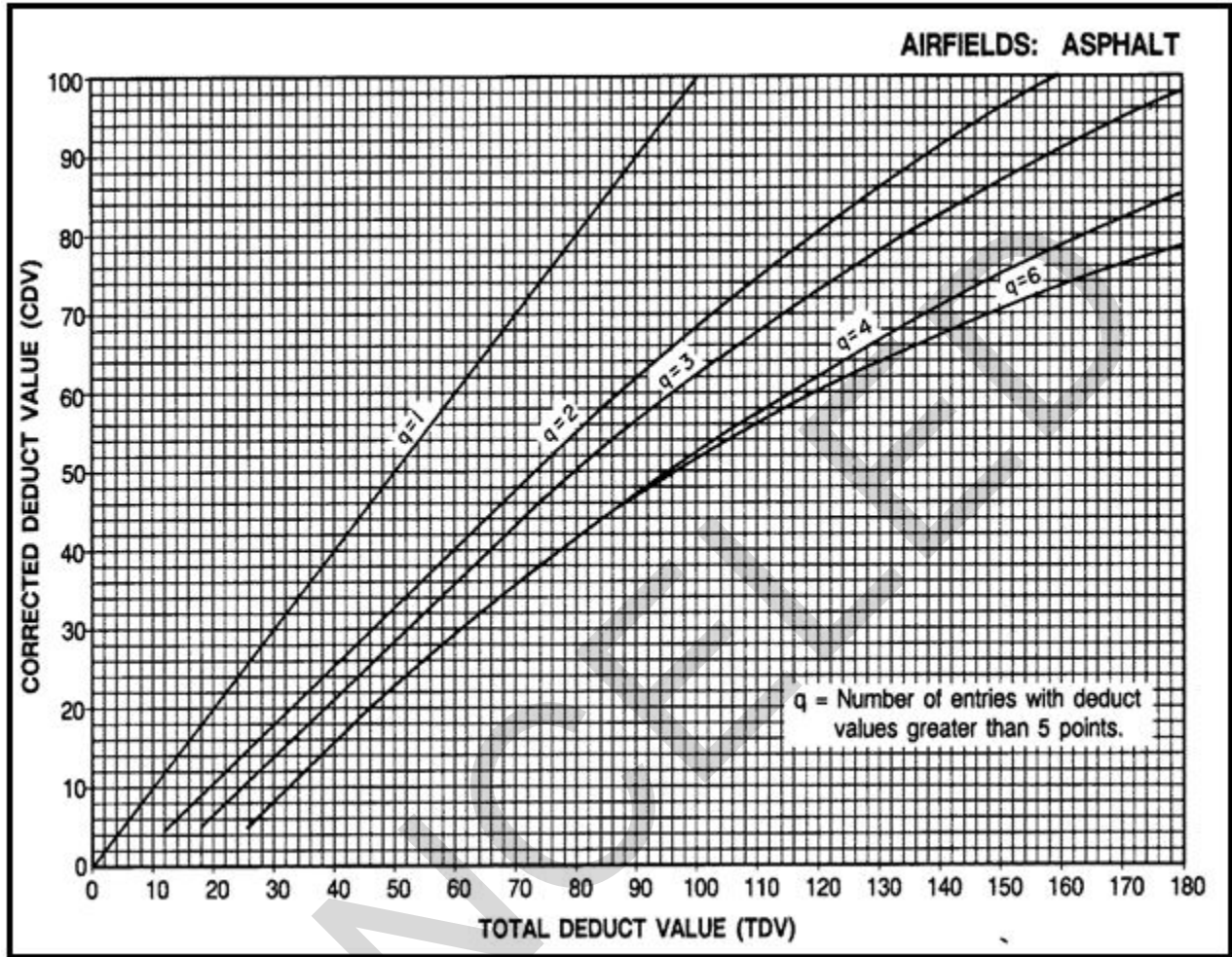

Figure C-20 Correct Deduct Curves for Asphalt Airfields



APPENDIX D DEDUCT CURVES FOR CONCRETE AIRFIELD PAVEMENTS

Figure D-1 Deduct Curves for Blowup (61) {1}

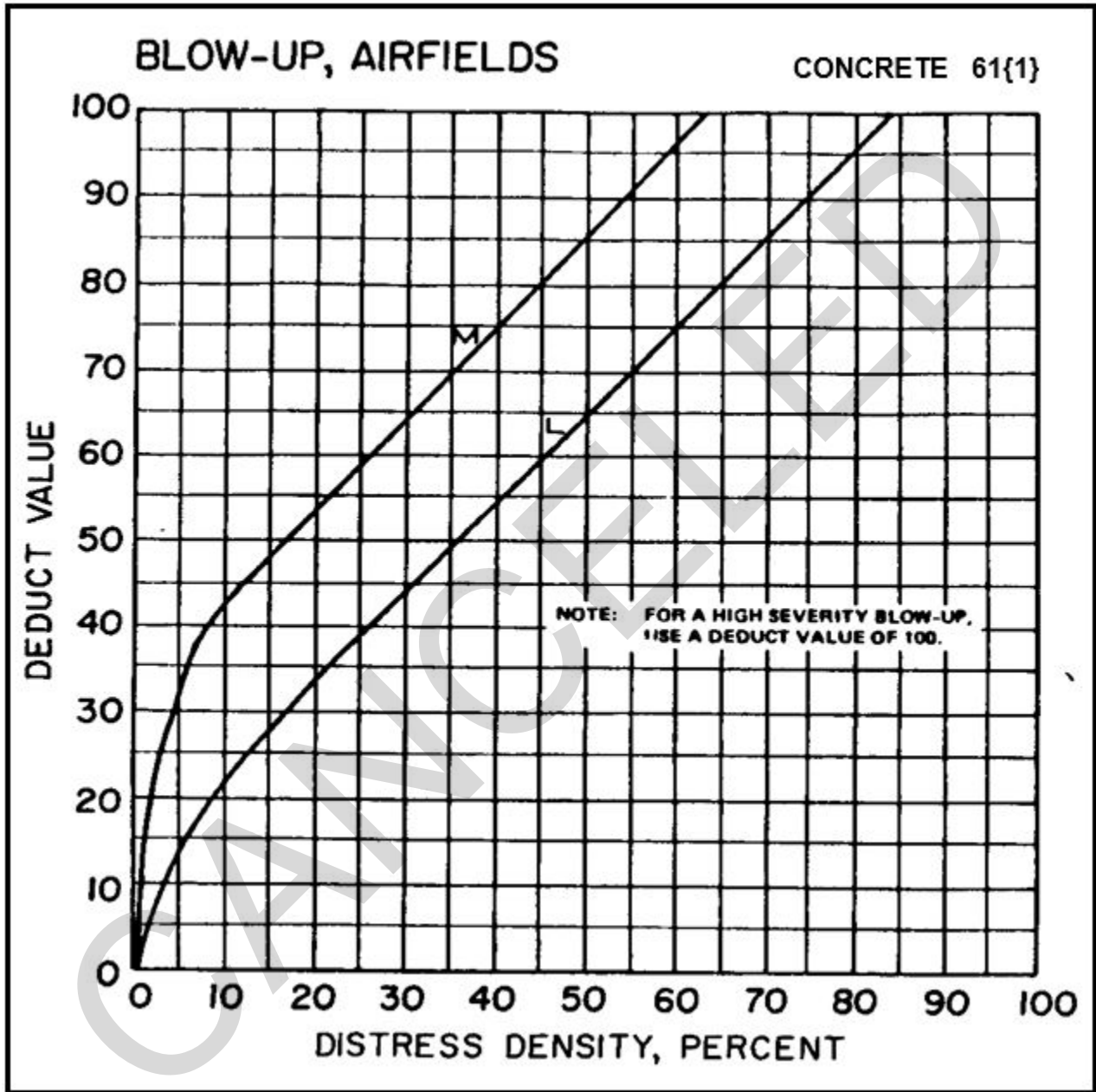

Figure D-2 Deduct Curves for Corner Break (62) {2}

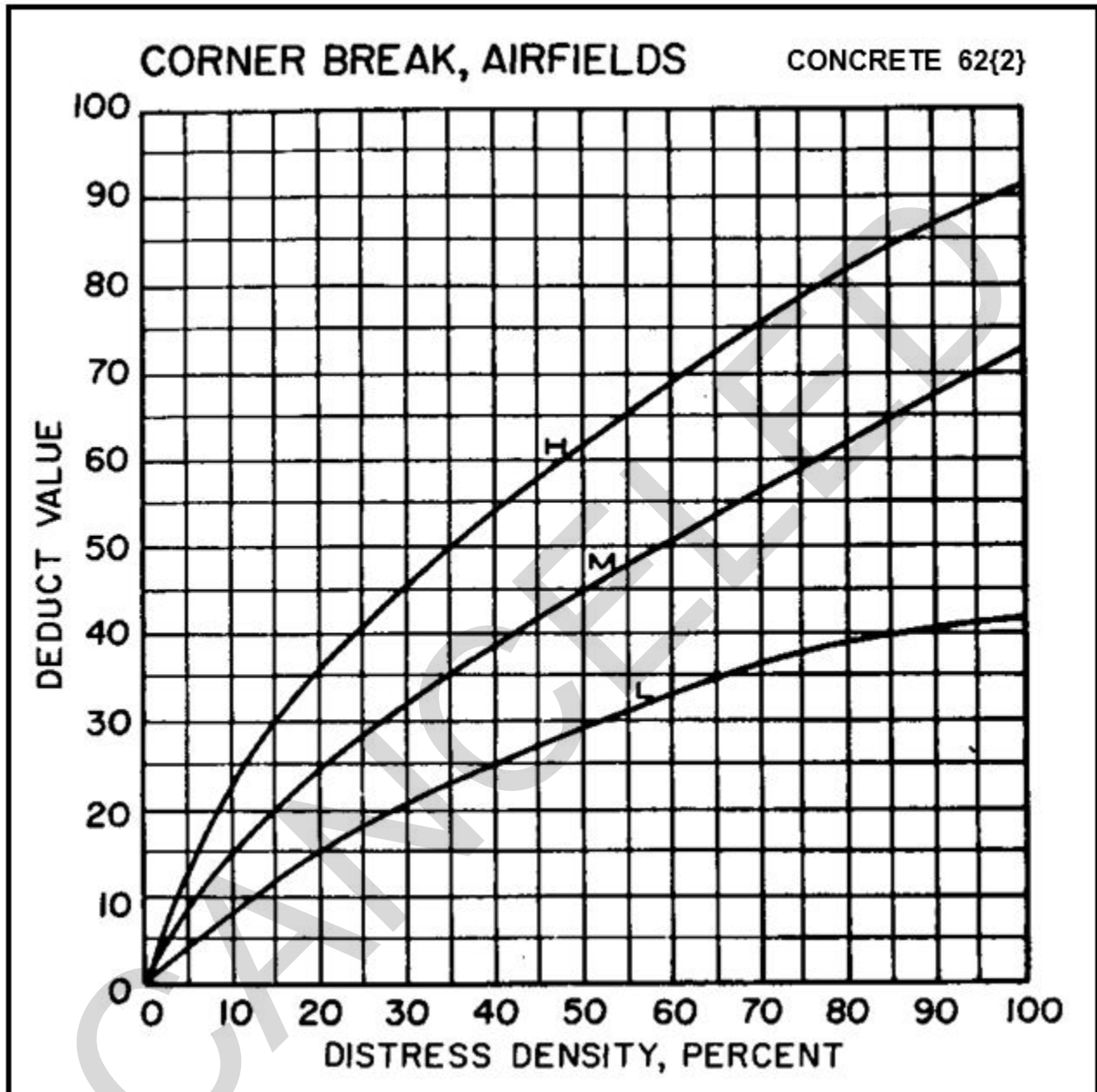

Figure D-3 Deduct Curves for Cracking (63) {3}

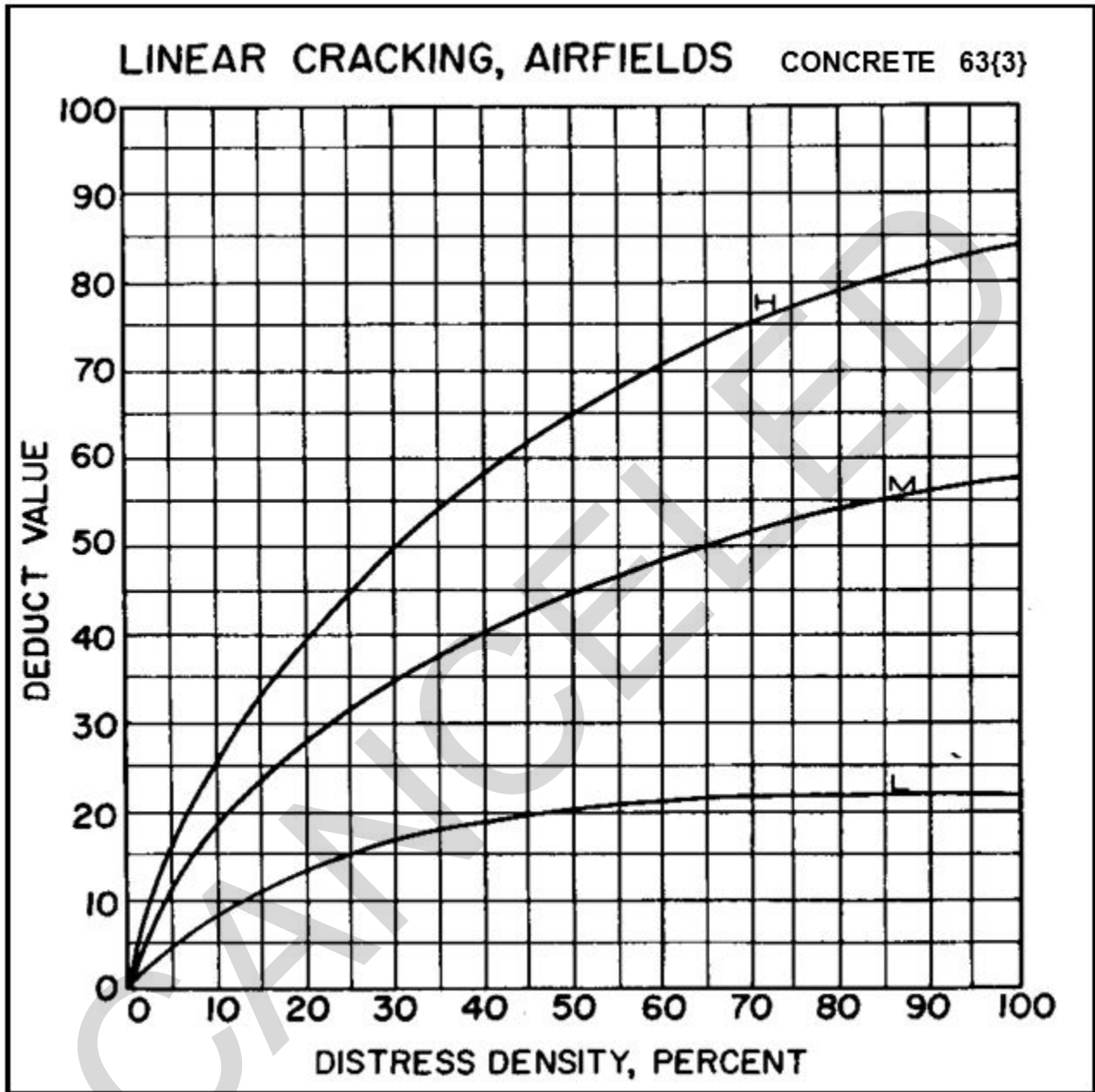

Figure D-4 Deduct Curves for Durability Cracking (64) {4}

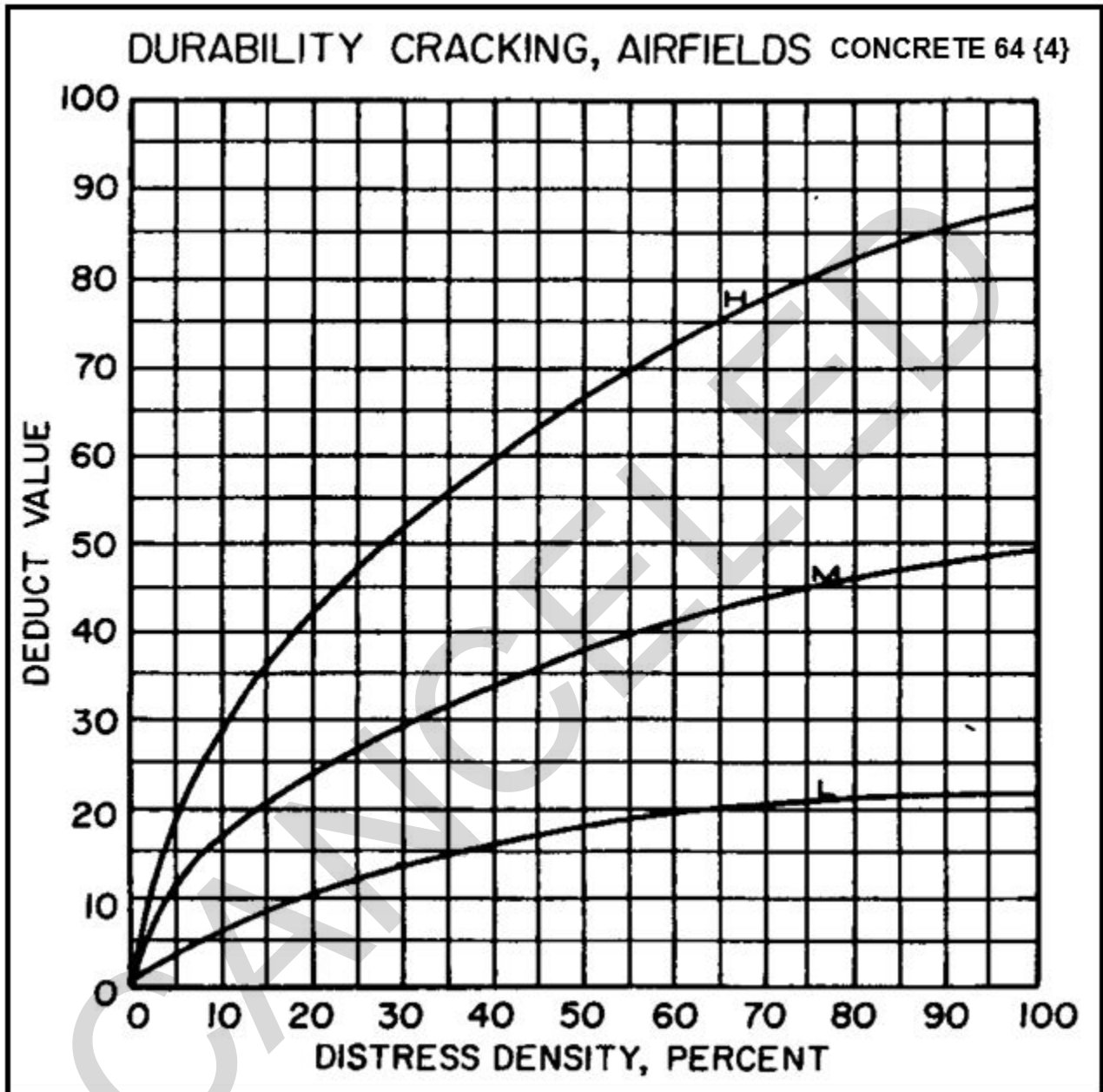

Figure D-5 Deduct Values for Joint Seal Damage (65) {5}

JOINT SEAL DAMAGE

Concrete 65 {5}

Joint seal damage is not rated by density. The severity of the distress is determined by the sealant's overall condition for a particular section.

The deduct values for the three levels of severity are as follows:

1. High Severity - 12 Points
2. Medium Severity - 7 Points
3. Low Severity - 2 Points

Figure D-6 Deduct Curves for Small Patch (66) {6}

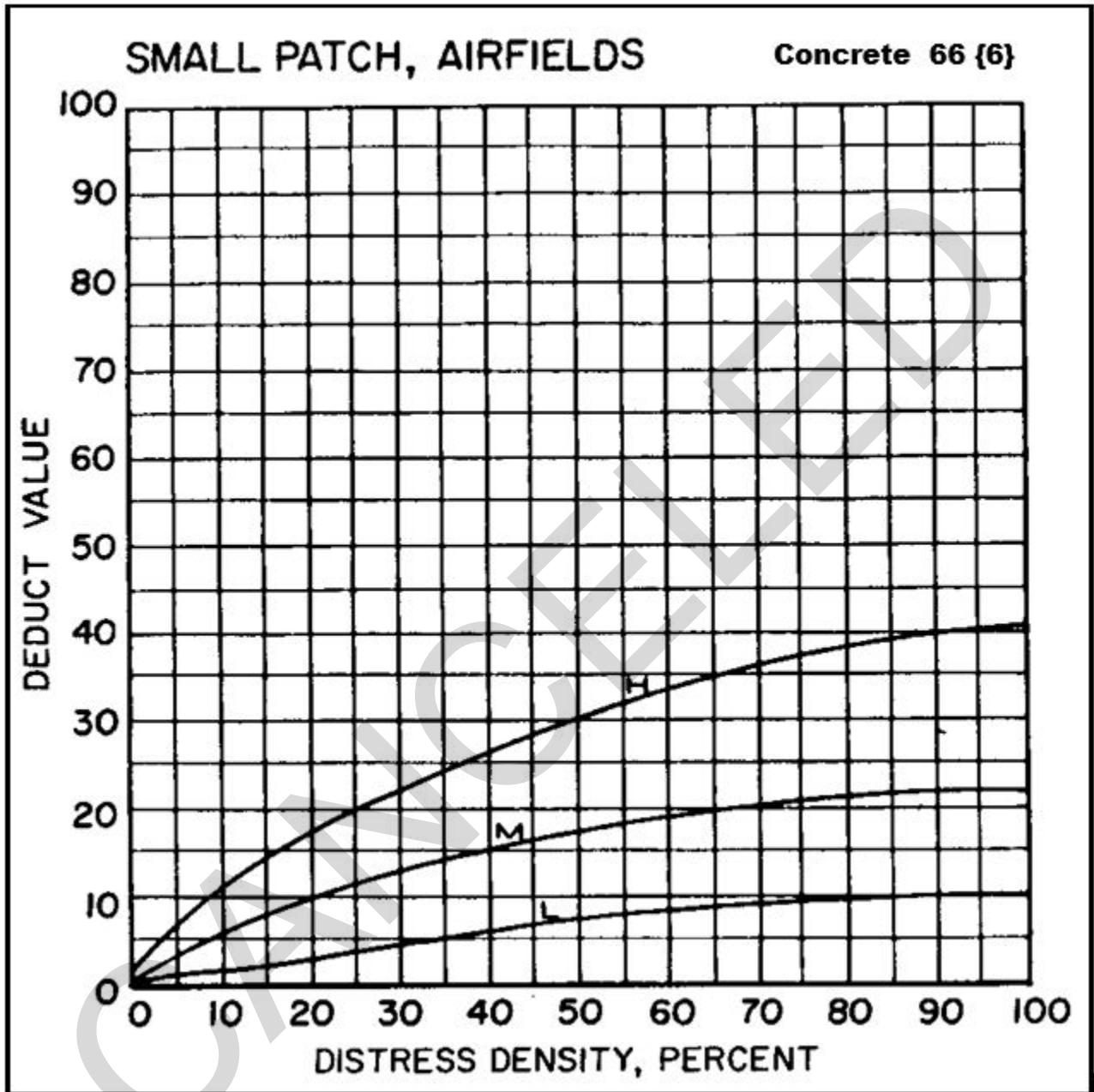

Figure D-7 Deduct Curves for Patching/Utility Cut (67) {7}

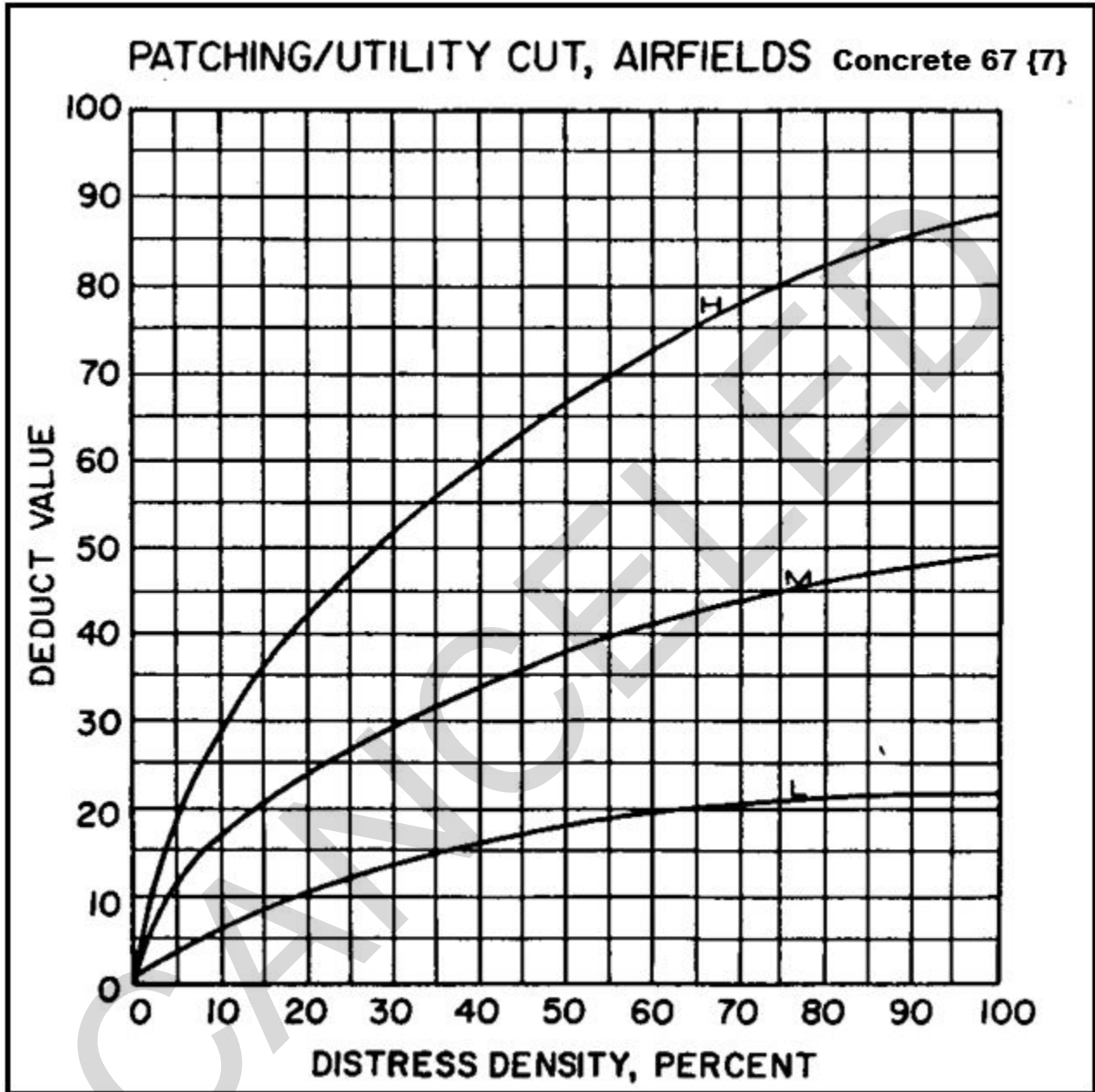

Figure D-8 Deduct Curve for Popouts (68) {8}

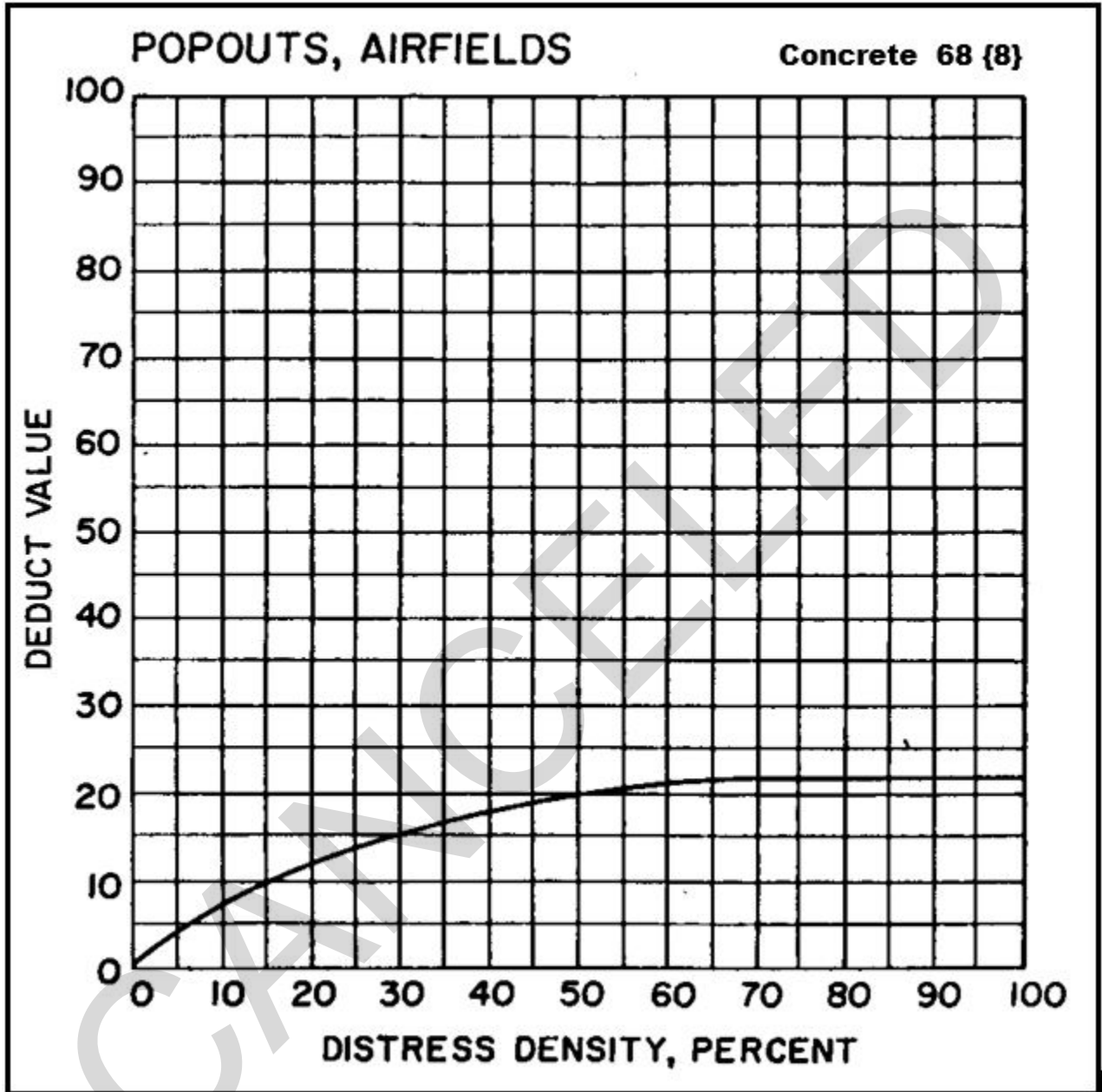

Figure D-9 Deduct Curve for Pumping (69) {9}

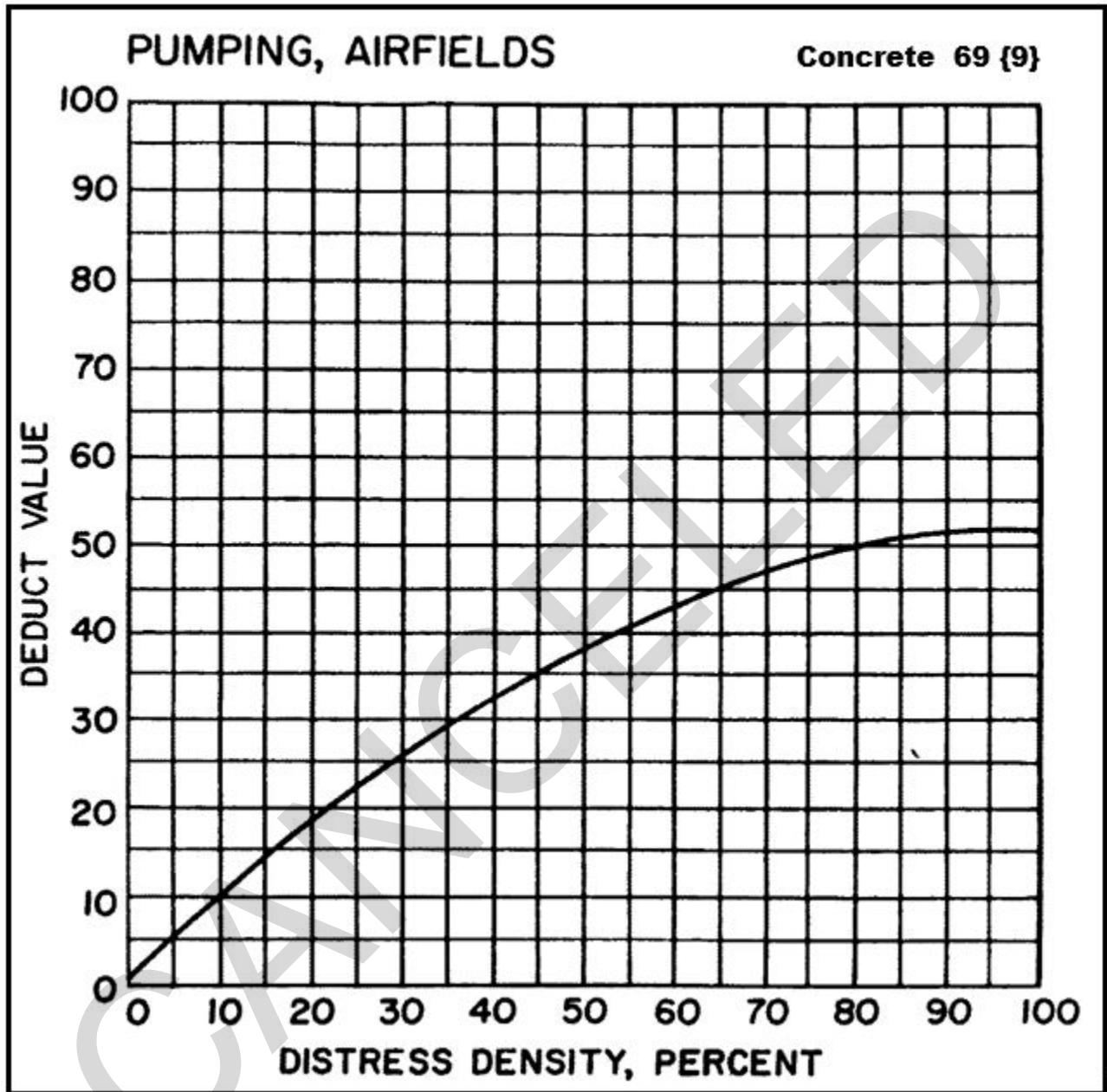

Figure D-10 Deduct Curves for Scaling (70) {10}

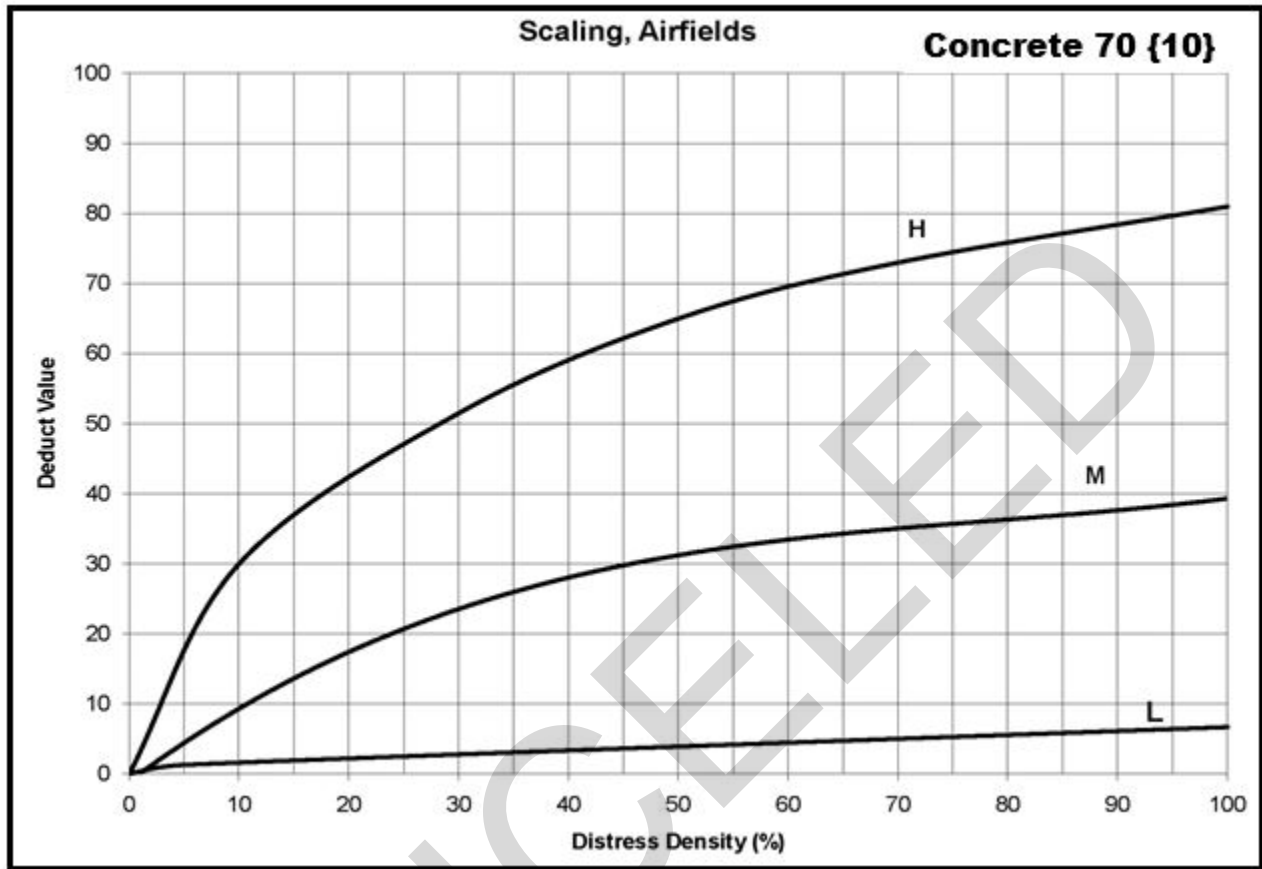

Figure D-11 Deduct Curves for Settlement (71) {11}

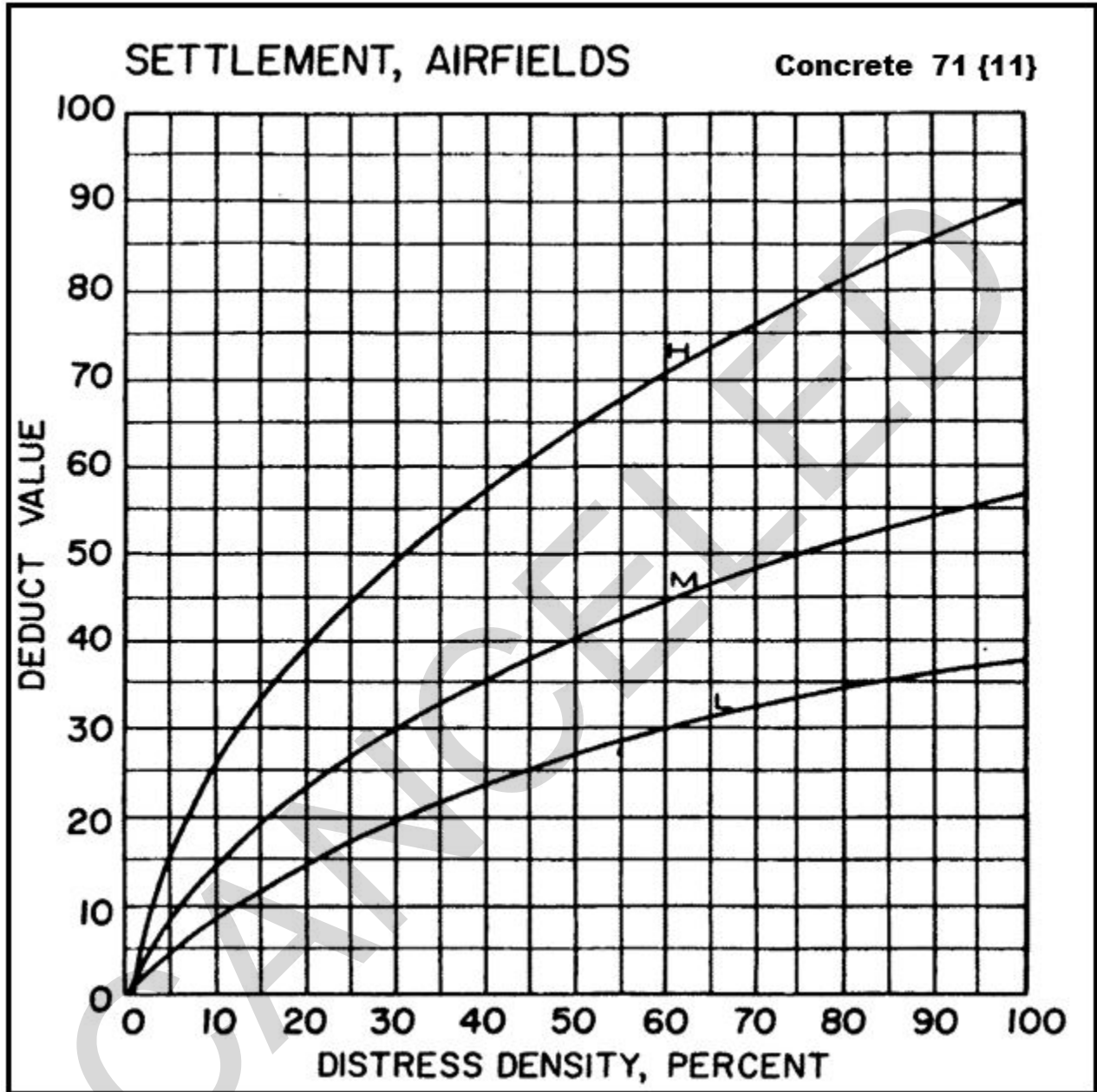

Figure D-12 Deduct Curves for Shattered Slab (72) {12}

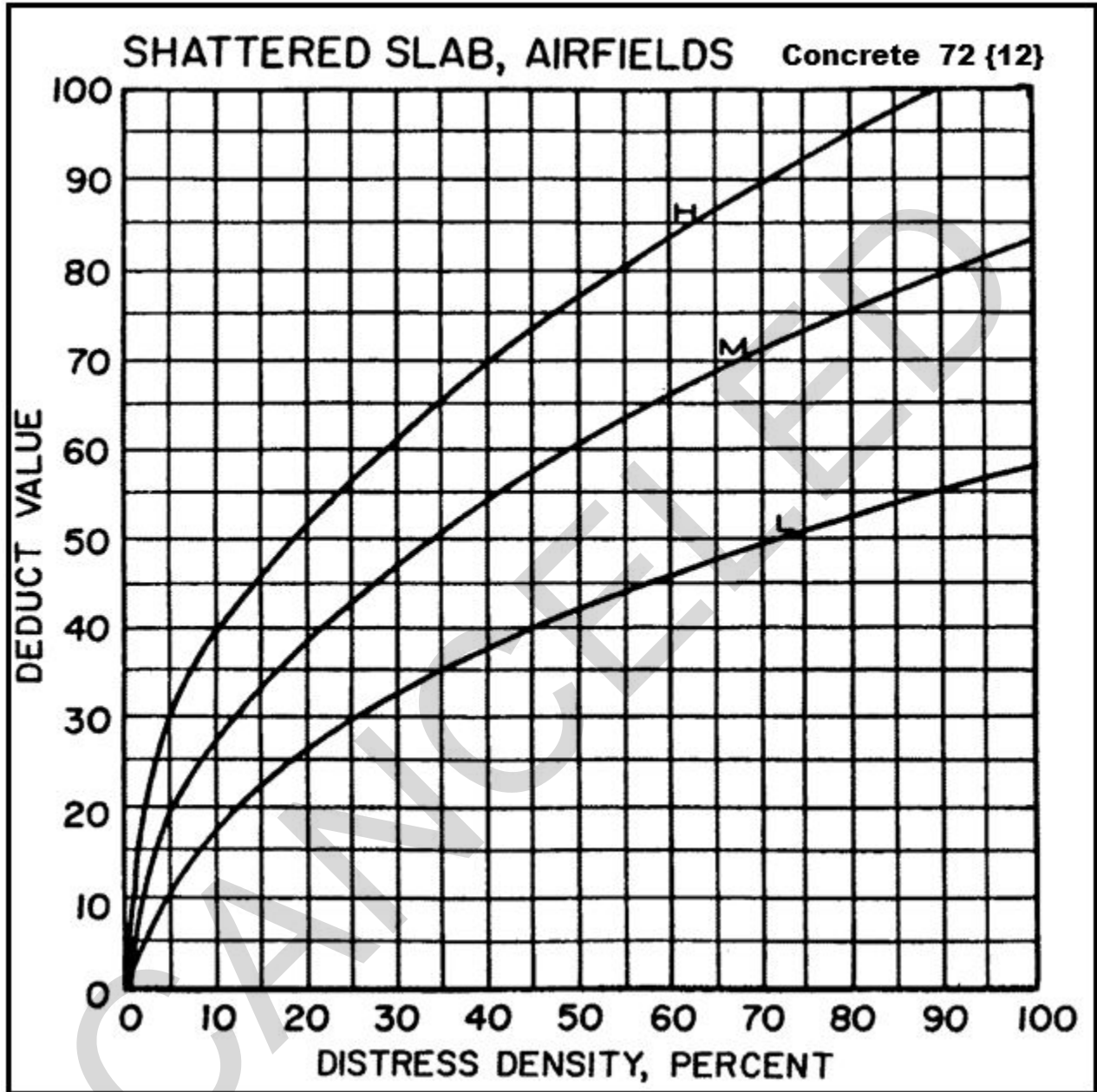

Figure D-13 Distress Curve for Shrinkage Cracks (73) {13}

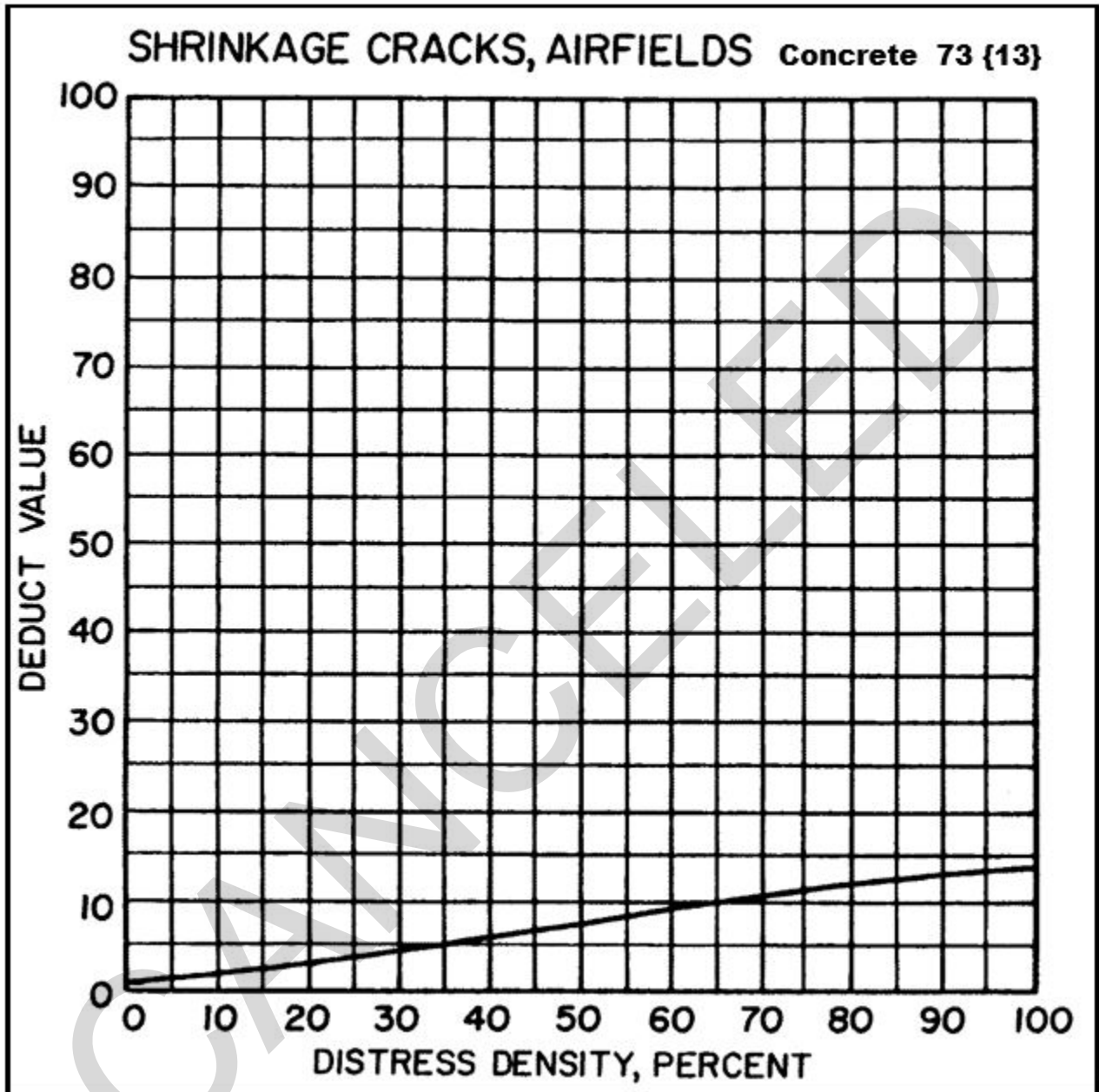

Figure D-14 Deduct Curves for Joint Spall (74) {14}

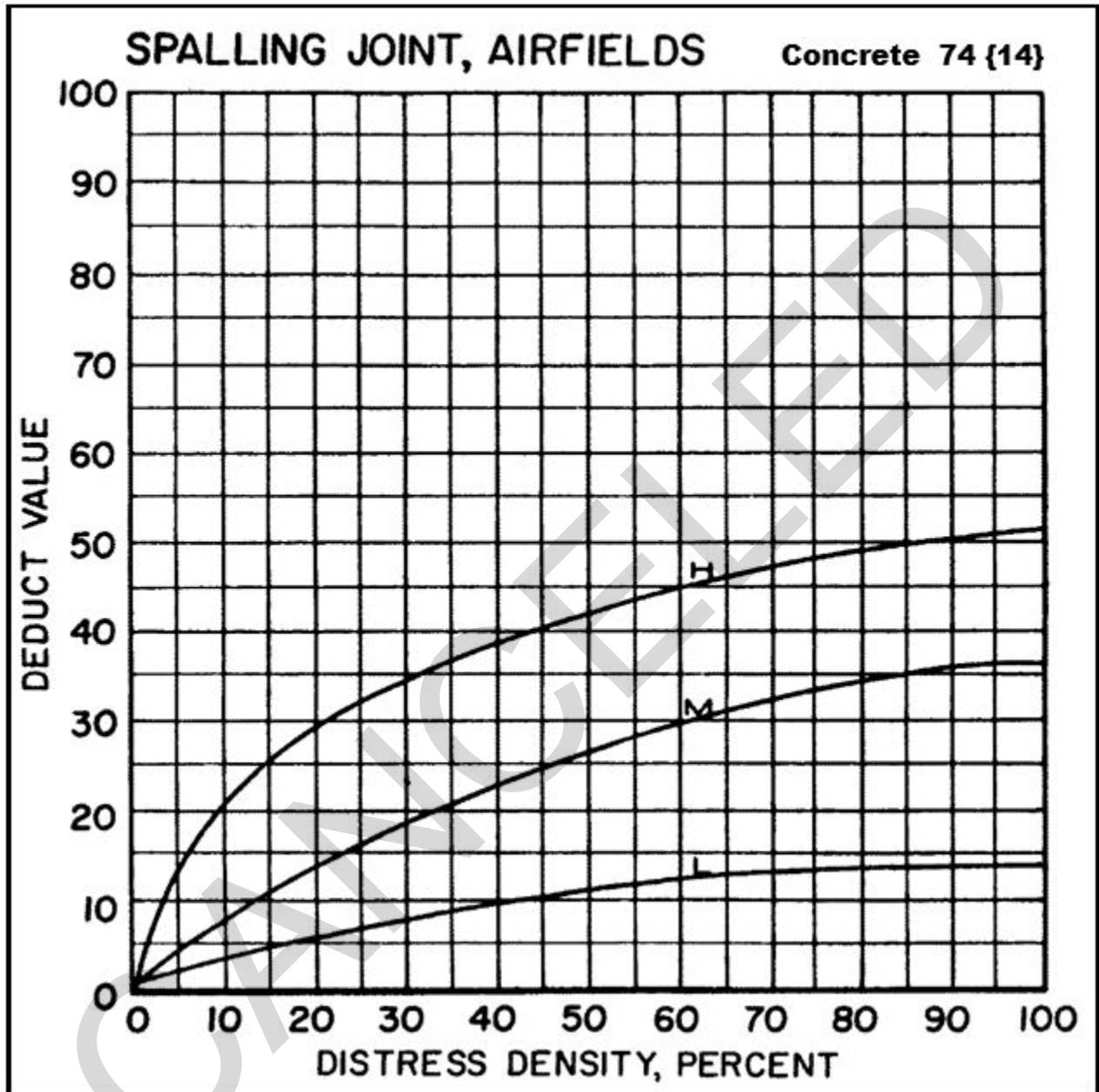

Figure D-15 Deduct Curves for Corner Spalling (75) {15}

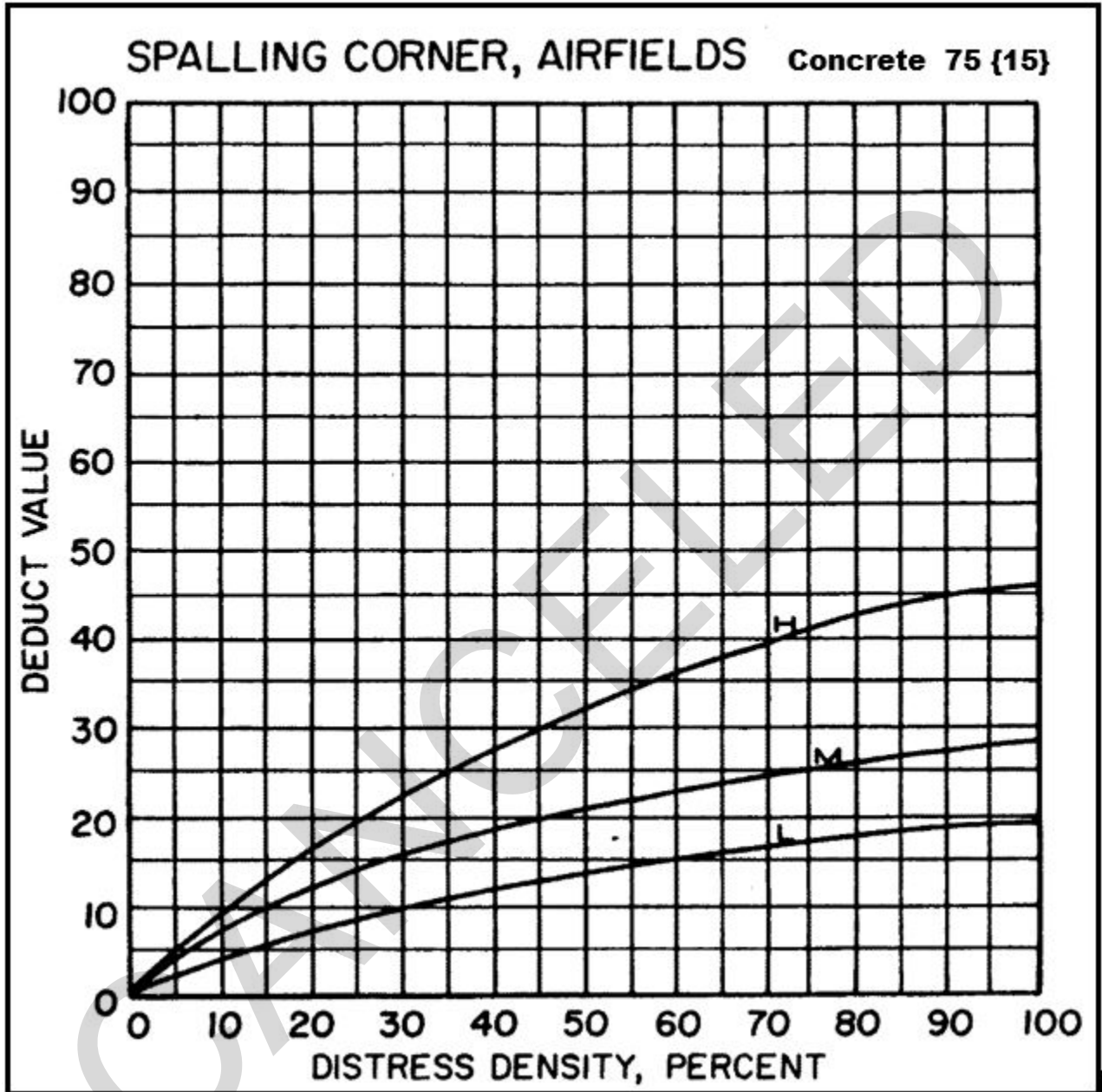

Figure D-16 Deduct Curves for ASR (76) {16}

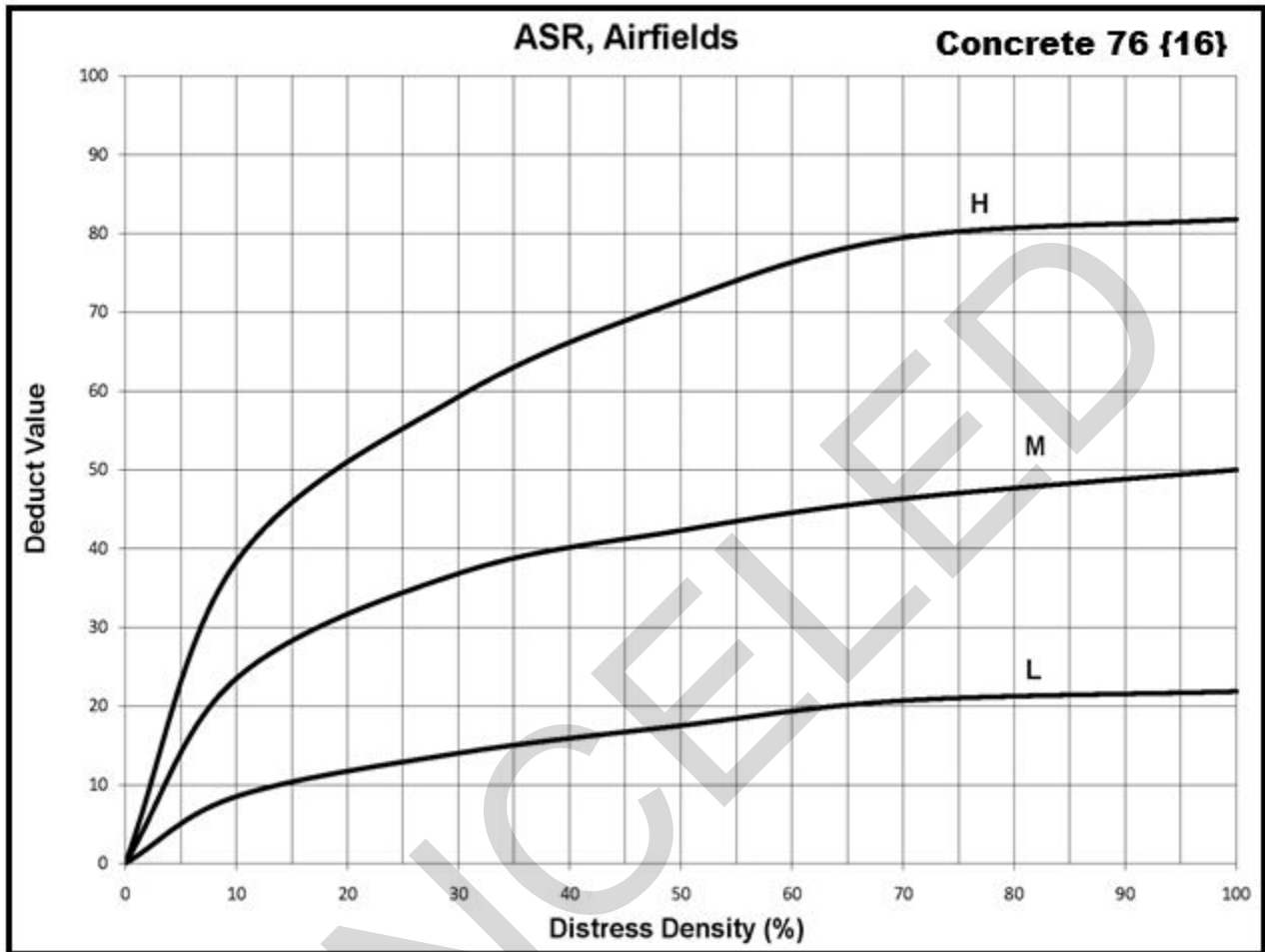
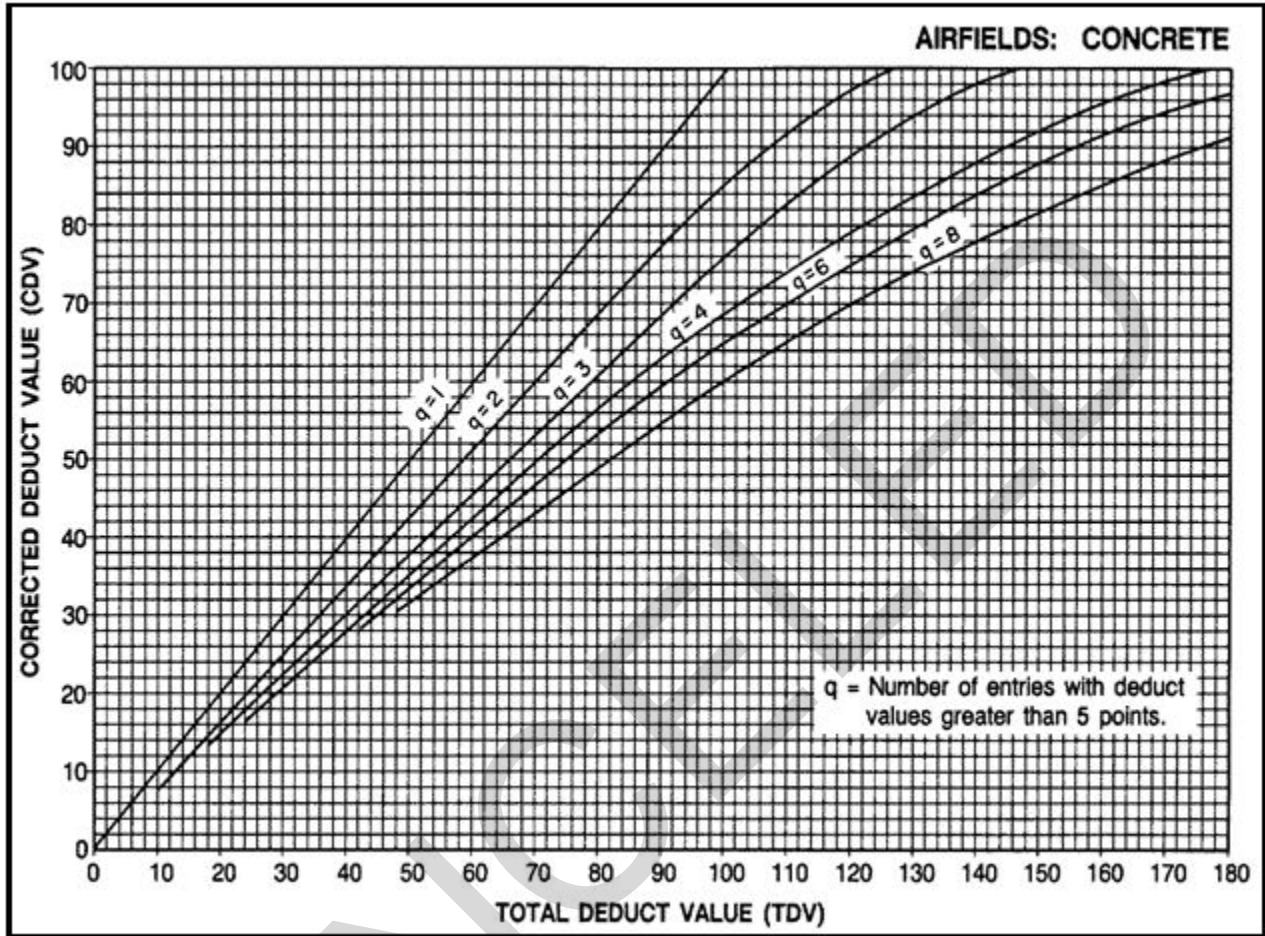

Figure D-17 Corrected Deduct Value Curves for Concrete



APPENDIX E BLANK FORMS.

CANCELLED

Figure E-3 AC Airfield Pavement Condition Survey Data Sheet (Automated)

AC Airfield Pavement Condition Survey Data Sheet (Automated)				
PID		INSPECTOR NAME		
FROM		BRANCH USE		DATE INSPECTED
TO		SECTION WIDTH		SECTION LENGTH
AC Surfaced Distress Codes				
41. Alligator Cracking {1}	46. Jet Blast {6}	51. Polished Aggregate {11}	56. Swell {16}	
42. Bleeding {2}	47. JT. Reflection (PCC) {7}	52. Raveling {12}	57. Weathering {17}	
43. Block Cracking {3}	48. Long. & Trans. Cracking {8}	53. Rutting {13}		
44. Corrugation {4}	49. Oil Spillage {9}	54. Shoving From PCC {14}		
45. Depression {5}	50. Patching {10}	55. Slippage Cracking {15}		
SAMPLE NUMBER		SAMPLE AREA		SKETCH/COMMENTS
DISTRESS CODE	L	M	H	

Figure E-4 PCC Airfield Pavement Condition Survey Data Sheet (Automated)

AC Airfield Pavement Condition Survey Data Sheet (Automated)				
PID		INSPECTOR NAME		
FROM		BRANCH USE		DATE INSPECTED
TO		SECTION WIDTH		SECTION LENGTH
AC Surfaced Distress Codes				
41. Alligator Cracking {1}		46. Jet Blast {6}		51. Polished Aggregate {11}
42. Bleeding {2}		47. JT. Reflection (PCC) {7}		52. Raveling {12}
43. Block Cracking {3}		48. Long. & Trans. Cracking {8}		53. Rutting {13}
44. Corrugation {4}		49. Oil Spillage {9}		54. Shoving From PCC {14}
45. Depression {5}		50. Patching {10}		55. Slippage Cracking {15}
56. Swell {16}		57. Weathering {17}		
SAMPLE NUMBER		SAMPLE AREA		SKETCH/COMMENTS
DISTRESS CODE	L	M	H	

Figure E-5 PCI Calculation Form

PCI CALCULATION FORM													
BRANCH			SECTION				SAMPLE UNIT						
CALCULATED BY			DATE										
Adjustment of the Number of Deduct Values (1 Minimum, 10 Maximum):													
ITERATION NUMBER	DEDUCT VALUES (Arrange Values from Highest Value to Lowest Value)										DEDUCT TOTAL	Number of Deduct Values Greater than (but not equal to) 5.0 q	Corrected Deduct Value CDV
	* Do not list more values than the Adjustment Number of Deduct Values (round to the next higher integer if a fraction/decimal)												
	** The last (lowest) value listed may be a fraction of one of the DEDUCT VALUES in the Condition Survey Data Sheet												
1													
2													
3													
4													
5													
6													
7													
8													
9													
10													
MAXIMUM CDV =													
Corrected Pavement Condition Index (PCI) = 100 - MAXIMUM CDV =													

APPENDIX F GLOSSARY

F-1 ACRONYMS.

AC	asphalt concrete
ASR	alkali-silica reaction
CDV	corrected deduct value
DOD	Department of Defense
FOD	foreign object damage
ft	foot
ft ²	square foot
HDV	highest deduct value
in.	inch
L&T	longitudinal and transverse
m ²	square meter
mm	millimeter
PCC	portland cement concrete
PCI	pavement condition index
PFC	porous friction course
UFC	Unified Facilities Criteria
UFC	Unified Facilities Manual

F-2 DEFINITIONS OF TERMS

Additional sample — a sample unit inspected in addition to the random sample units to include non-representative sample units in the determination of the pavement condition. This includes very poor or excellent samples that are not typical of the section and sample units that contain an unusual distress such as a utility cut, oil spillage, or jet blast. If a sample unit containing an unusual distress is chosen at random, it should be counted as an additional sample unit and another random sample unit should be chosen. If every sample unit is surveyed then there are no additional sample units.

Asphalt concrete (AC) surface — aggregate mixture with an asphalt cement binder. This term also refers to surfaces constructed of coal tars and natural tars for purposes of this test method. Sometimes referred to as a flexible pavement.

Deduct value (DV) — a number from 0 to 100, with 0 indicating the distress has no impact on pavement condition and 100 indicating an extremely serious distress that causes the pavement to fail.

Pavement branch — a branch is an identifiable part of the pavement network that is a single entity and has a distinct function. For example, each runway or taxiway is a separate branch.

Pavement condition index (PCI) — a numerical rating of the pavement condition that ranges from 0 to 100 with 0 being the worst possible condition and 100 being the best possible condition.

Pavement condition rating (PCR) — a verbal description of pavement condition as a function of the PCI value. This AEP establishes a standard color code for the seven condition codes developed by DOD and also for a corresponding simplified PCI rating system of Good (PCI = 71 to 100), Fair (PCI = 56 to 70), and Poor (PCI = 0 to 55), as depicted in Figure F-1. This system was adopted by and is also described in ASTM D5340.

Figure F-1 Pavement Condition Index (PCI) and Simplified PCI Rating Scales

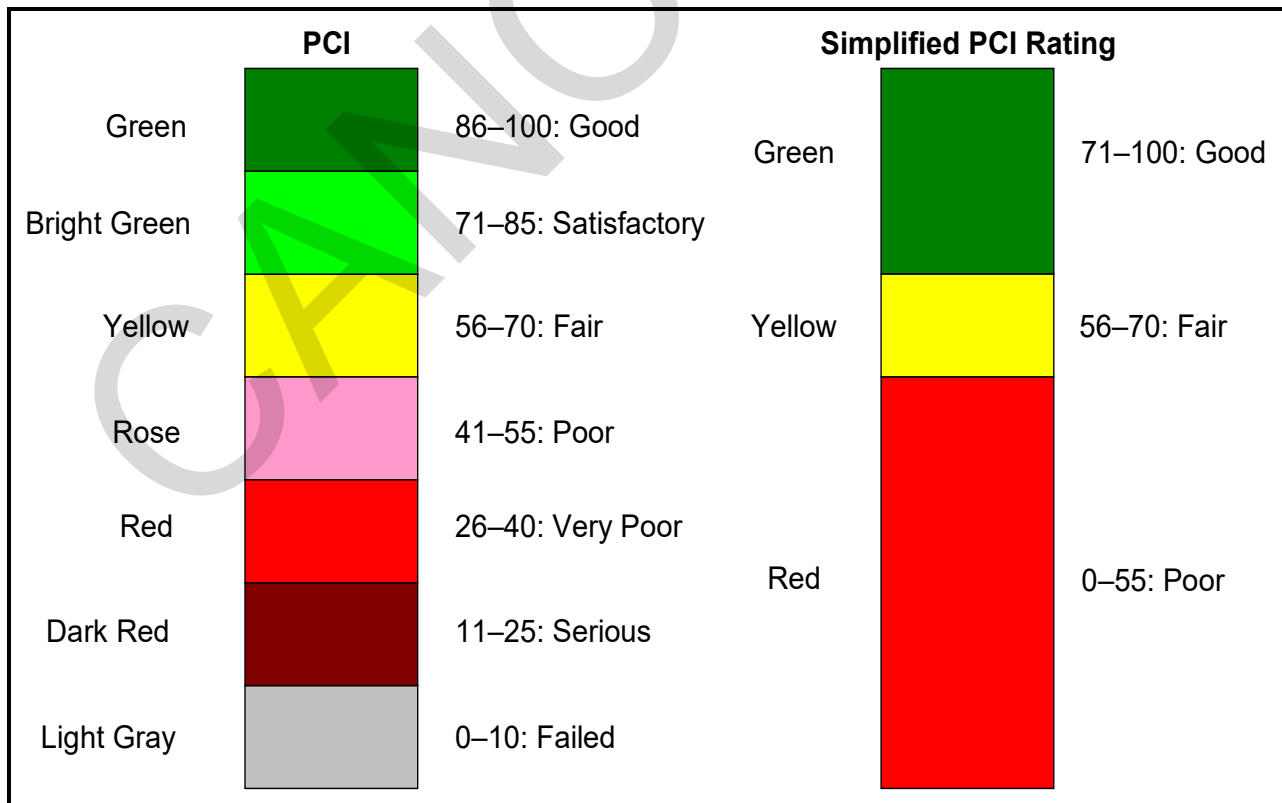

Pavement distress — external indicators of pavement deterioration caused by loading, environmental factors, construction deficiencies, or a combination thereof. Typical distresses are cracks, rutting, and weathering of the pavement surface. Distress types and severity levels detailed in Appendix A for AC and Appendix B for PCC pavements must be used to obtain an accurate PCI value.

Pavement sample unit — a subdivision of a pavement section that has a standard size range: 20 slabs (± 8 slabs if the total number of slabs in the section is not evenly divided by 20, or to accommodate specific field condition) for PCC pavement, and contiguous 5000 square feet \pm 2000 square feet (465 square meters \pm 185 square meters) if the pavement is not evenly divided by 5000 (or to accommodate specific field condition) for AC pavement.

Pavement section — a pavement area having uniform construction, maintenance, usage history, and condition. A section should have the same traffic volume and load intensity.

Portland cement concrete (PCC) pavement — aggregate mixture with portland cement binder including non-reinforced and reinforced jointed pavement. Sometimes referred to as a rigid pavement.

Random sample — a sample unit of the pavement section selected for inspection by random sampling techniques such as a random number table or systematic random procedure.

Primary Pavement — mission-essential pavements such as runways, parallel taxiways, main parking aprons, arm-disarm pads, alert aircraft pavements, turnabouts (hammer heads), and overruns (when the overrun is used as a taxiway or for takeoff roll). In general, only pavements that have aircraft use on a daily basis or frequently used transient taxiways and parking areas are considered primary.

Secondary Pavement — mission-essential but occasional-use airfield pavements, including ladder taxiways, infrequently used transient taxiway and parking areas, overflow parking areas, and overruns (when there is an aircraft arresting system present). In general, any pavements that do not have daily use by aircraft are secondary.

Tertiary Pavement — includes pavements used by towed or light aircraft, such as maintenance hangar access aprons, wash racks, overruns (when not used as a taxiway or to test aircraft arresting gear), and paved shoulders. In general, any pavement that does not support aircraft taxiing under their own power, areas where jet blast is limited, or is used only intermittently by aircraft is considered a tertiary pavement.

APPENDIX G REFERENCES

DEPARTMENT OF DEFENSE

STANAG 7181 Ed. 1, *Standard Method for Airfield Pavement Condition Index (PCI) Surveys*, 2009, Executive Agent for the Defense Standardization Program Office, 8725 John J. Kingman Rd, Stop 5100, Fort Belvoir, VA, 22060-6220, <http://www.assistdocs.com/>

AIR FORCE

Development of a Pavement Maintenance Management System, Vol. I-V, 1976-1977, Shahin, M.Y., Darter, M.I., and Kohn, S.D., U.S. Air Force Engineering Services Center (AFESC), Tyndall AFB, Florida, <https://apps.dtic.mil/sti/citations/ADA082340>

ASTM INTERNATIONAL

ASTM D5340, *Standard Test Method for Airport Pavement Condition Index Surveys*, <https://www.astm.org/>

CANCELLED